

HIS MAJESTY'S GOVERNMENT  
DEPARTMENT OF ARCHAEOLOGY



**AYUGUTHI SATTAL**  
PATAN DARBAR SQUARE, WARD 11

**HISTORIC STRUCTURE REPORT**  
**JANUARY, 1996**

**ERICH G. THEOPHILE**  
**ROHIT K. RANJITKAR**

**KATHMANDU VALLEY PRESERVATION TRUST**  
**IN COOPERATION WITH**  
**HMG DEPARTMENT OF ARCHAEOLOGY**

## Table of contents

	page
1.0 Introduction/Brief History .....	4
2.0 Construction History .....	7
3.0 Architectural Description .....	15
3.1 Traditional Building Techniques .....	16
3.2 Iconography: Carvings .....	20
<b>4.0 Existing Conditions .....</b>	<b>27</b>
4.01 Foundation/walls: structural .....	27
4.02 Wall Fabric .....	29
4.03 Walls: Timber Elements/Openings .....	29
4.04 Roof and floor Structure .....	32
4.05 Roof Cover and Decorative Elements .....	34
4.06 Interior .....	34
<b>5.0 Recommendation for Repairs .....</b>	<b>35</b>
5.0 Introduction to critical conservation issues .....	35
5.01 Foundation/ walls structural: seismic reinforcements .....	37
5.02 Wall Fabric: Damp proof Course .....	41
5.03 Wall openings and Decorative Elements .....	42
5.04 Roof and Floor Structure .....	42
5.05 Roof Cover .....	45
5.06 Interior .....	47
6.0 Bibliography .....	48

## Drawings

Patan City Map .....	1
Patan Protected Monument Zone .....	2
Patan Darbar Square: Axonometric (Sekler, 1987) .....	3
Patan Darbar Square: North Elevation (Sekler, 1987) .....	5
Existing South-North Section .....	8
Principal South Elevation, Construction History .....	8A
Ground, First Floor Plans: Existing Conditions .....	28
Principal South Elevation, Existing Conditions .....	28A
Existing South-North Section, Annotated .....	28B
Seismic retrofitting, details of other Trust projects .....	39
Proposed seismic reinforcement of Ayuguthi, Section .....	40
Detail of existing/improved timber peg .....	44

## Appendices

(A1) A traditional legend/list of guthiars .....	A1
(A2) Brief on nationalization of the structure: 5/95, 3/96 .....	A2
(A3) Technical information .....	A3
(A4) Cost estimate for proposed repairs, January 1996 .....	A17

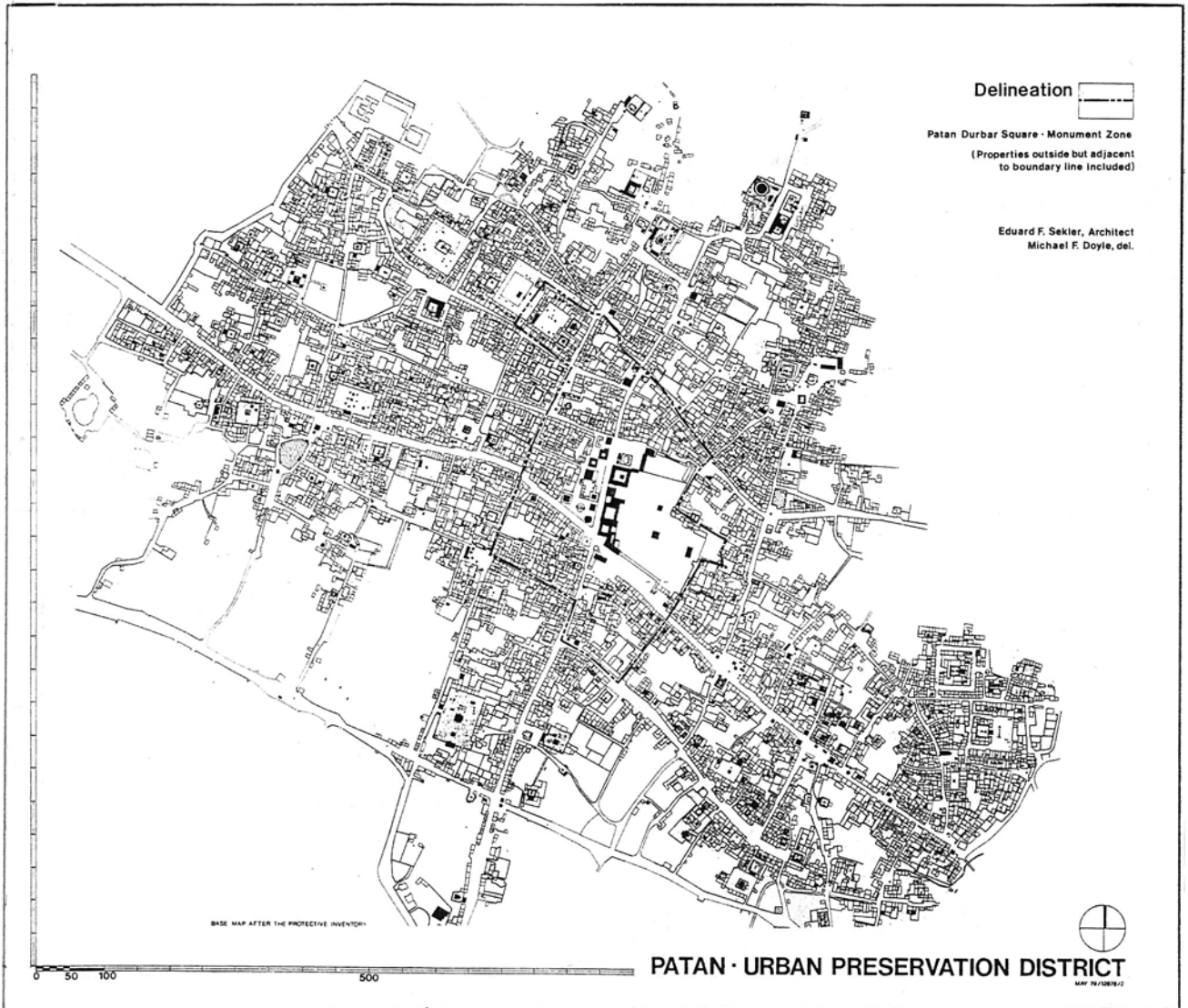

Above: Patan city plan, Sekler, 1979. Below: view of the northern edge of Patan Darbar Square with Mani Ganesh Temple centre, Ayuguthi Sattal, right.



### Existing Monument Zone/World Heritage Site

Shaded areas depict significant architectural ensembles of houses at critical edges of the present boundary.

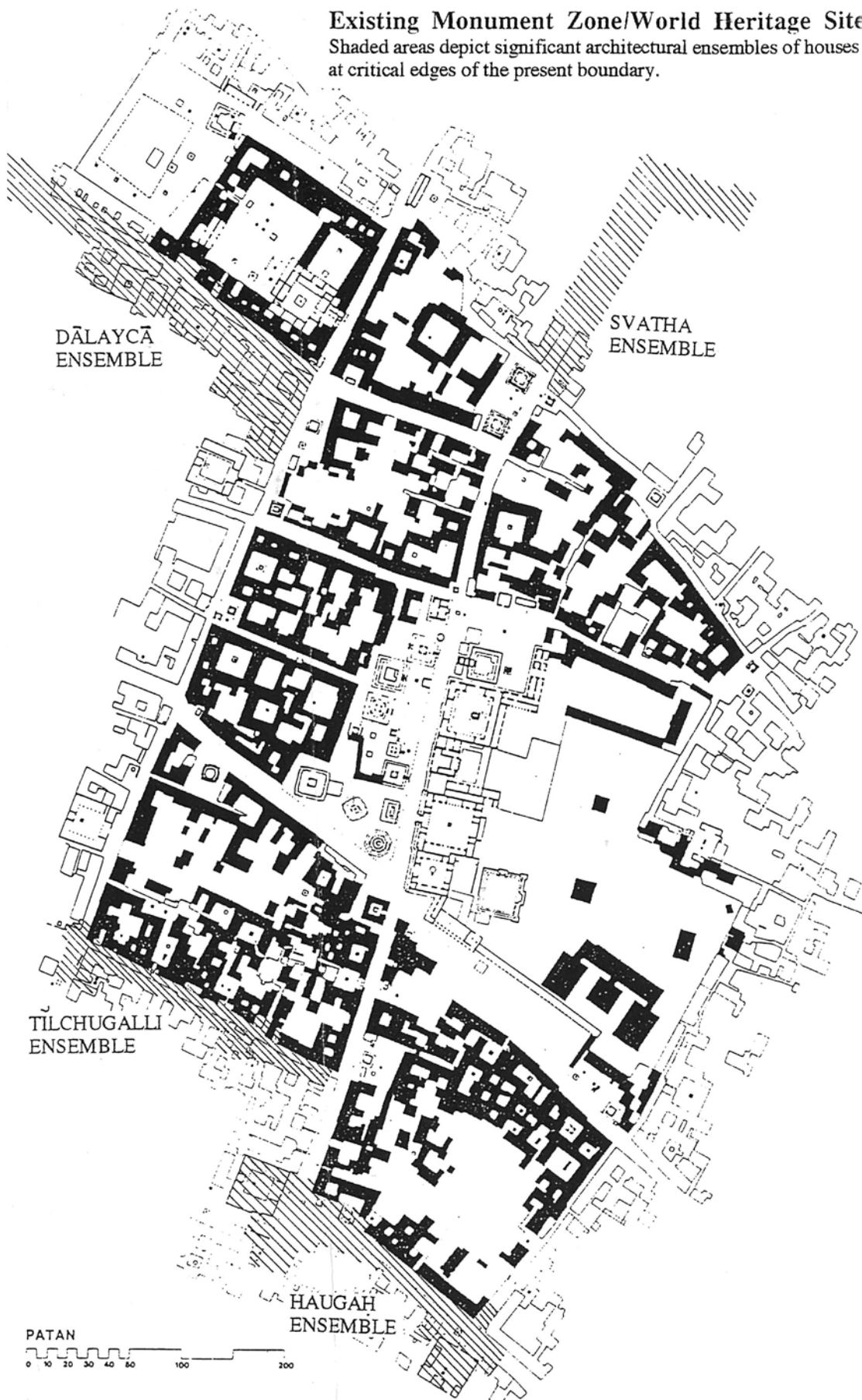

Patan Darbar World Heritage Site: Blackened areas defining the royal square and garden are included protected Monument Zone as gazetted by HMG; Ayuguthi Sattal shown in red.

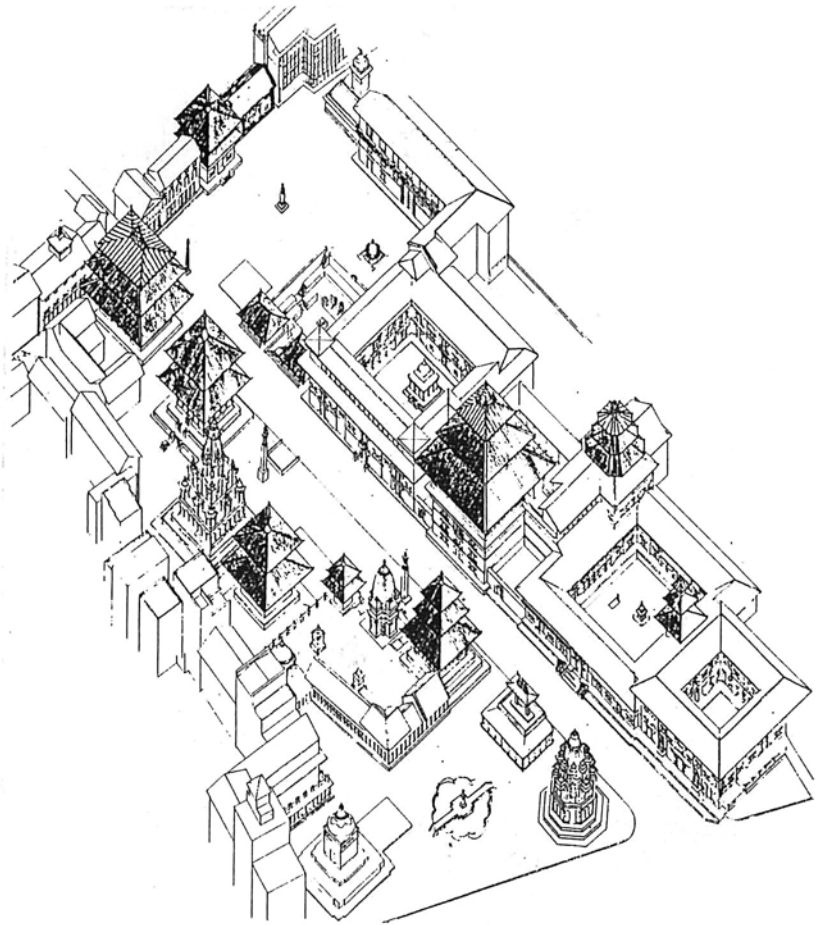

Right: Axonometric of Patan Darbar Square (Sekler 1979). Ayuguthi Sattal shown in red. Below: Principal elevation of Ayuguthi Sattal after shoring up by Trust, February 1992.

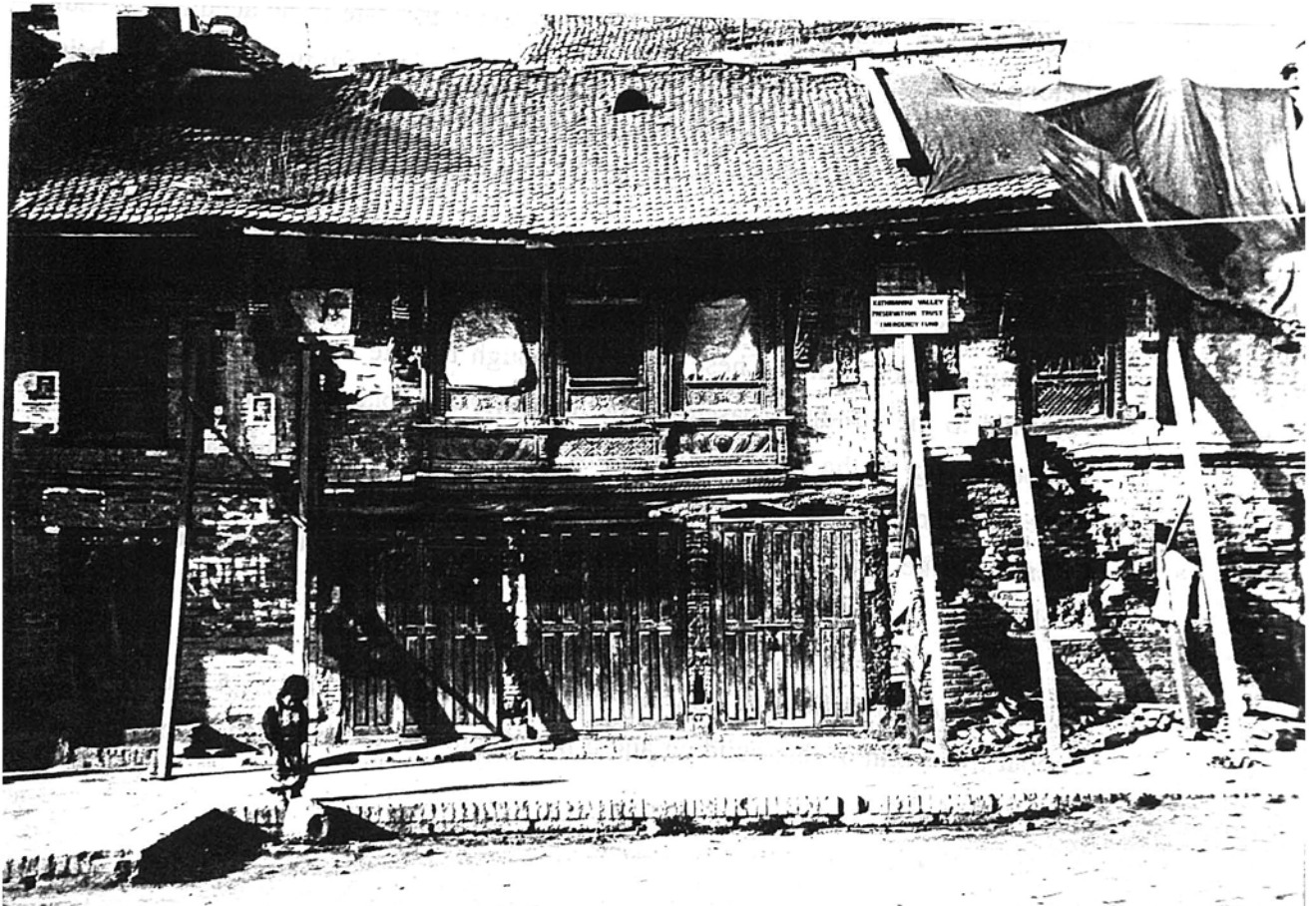

## 1.0 INTRODUCTION/ BRIEF HISTORY

The Ayuguthi Sattal has been the focus of KVPT and Department of Archaeology efforts since 1991, when the Trust in collaboration with HMG Department of Archaeology initiated emergency repairs. This work included temporary roof cover and propping up of the structure by Architect Surya Bhakta Sangacche to prevent further deterioration.

Urbanistically, the building is of prime importance forming the northern edge of the Patan Darbar Square, a UNESCO World Heritage Site. Architecturally, the dilapidated structure possibly dated to 1703 A.D. retains many historical carved features and is an important example of the diminutive two story resthouse (Nepali: *sattal, pati*; Newari: *sattah, phalca*) building type. The square may in past centuries have been defined by more of these structures, of which Ayuguthi Sattal and Lampati (at the southern end of the square) are the only survivors.

The National Census of B.S. 2031 (A.D. 1974) on record at Lalitpur Nagar Palika lists the structure as "the common sattal of Babulal, house no. 35, block # "kha", ward # 11, construction date Samvat 1760." This date is not found in any other inscriptions or published literature. If one assumes the date to be accurate, it could belong to one of two calendars, Bikram Samvat or Sake Samvat, the former being more likely for a public record. If the date is Bikram Samvat, then  $\text{Samvat } 1760 - 57 = 1703 \text{ A.D.}$  If Sake Samvat, then the construction date would be  $\text{Sake } 1760 + 137 = 1897 \text{ A.D.}$ <sup>1</sup>

Stylistically, the ground floor pillars' quality of carvings and massiveness suggest an 18th century dating. These pillars, although termite damaged, are most likely original to the building (based on the difficulty of replacing such elements). The woodcarving of the intact bay window (Newari: *san jhya*) and its diminutive size reinforce an eighteenth century dating. It is probable that other timber facade elements like struts and niche figures are not original to the structure (discussed below).

Thus, although difficult to confirm, the 1703 date seems likely. A traditional tale about the origin of this building and a list of guthiars are included in the appendix.

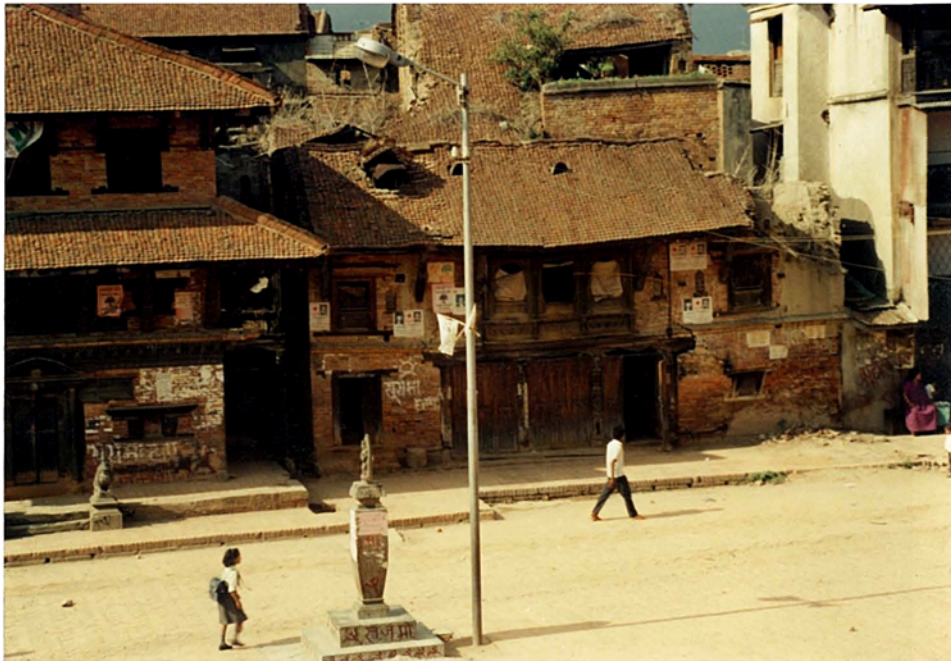

Above: spring 1991 before emergency shoring up. Below: north elevation of Patan Darbar (Sekler 1979)..



North Elevation

0 1 2 3 4 5m



Above: multi-bay window or san jhyah of principal facade, fall, 1993. Below: principal facade spring, 1994. Notice additional wall damage at far right.



### **Private monuments**

The building is an important test case for preservationists in Nepal as (1) the urgency of repairs merits action by the government and (2) the proposal to nationalize the structure is a landmark effort. If successful, this nationalization (with compensation) provides a key precedent for many significant monuments which are threatened by ownership disputes, misappropriated ownership, and/or lack of commitment to preserve. Particularly in the case of resthouses, the possibility to nationalize would allow certain threatened A-class monuments which were misassigned in the land surveys of the 1970's to be adopted by the government, and thus qualify for government funds and/or international assistance. See briefing on nationalization included in appendix.

## **2.0 CONSTRUCTION HISTORY**

### **Original shape of the building**

Before the coronation of the current king in 1975 and as part of the renovation of the adjacent Mani Ganesa Temple, the building's length was shortened approximately 6'-2" in the front and in the rear 6'-4". The former configuration is confirmed by historical photographs and the lack of cornice on the east side of the Ganesh Temple (where the temple was engaged by the old resthouse). If restored to its former length, the building would be symmetrical around its central axis at the central trabeate opening or *dalan*

The west end wall thus dates from 1974, constructed in new common brick (*ma apā*) and mud mortar.

The historical (pre-1974) roof configuration seems to have been asymmetrical: intact strut consoles at the southeastern corner establish that the former east end included a *pacha*, the hip-like overhang at the gable end, typical of local construction. This would have contrasted the double pent roof engaged by the adjacent and taller temple wall before shortening.

### **Carved timber**

Mortises and carving details in all seven extant roof struts establish that they come from a leaning bay window or *san jhya*. The quality of carving suggests an age of less than 100 years. Carved timber figures in the upper story niches also appear to have come from another structure.

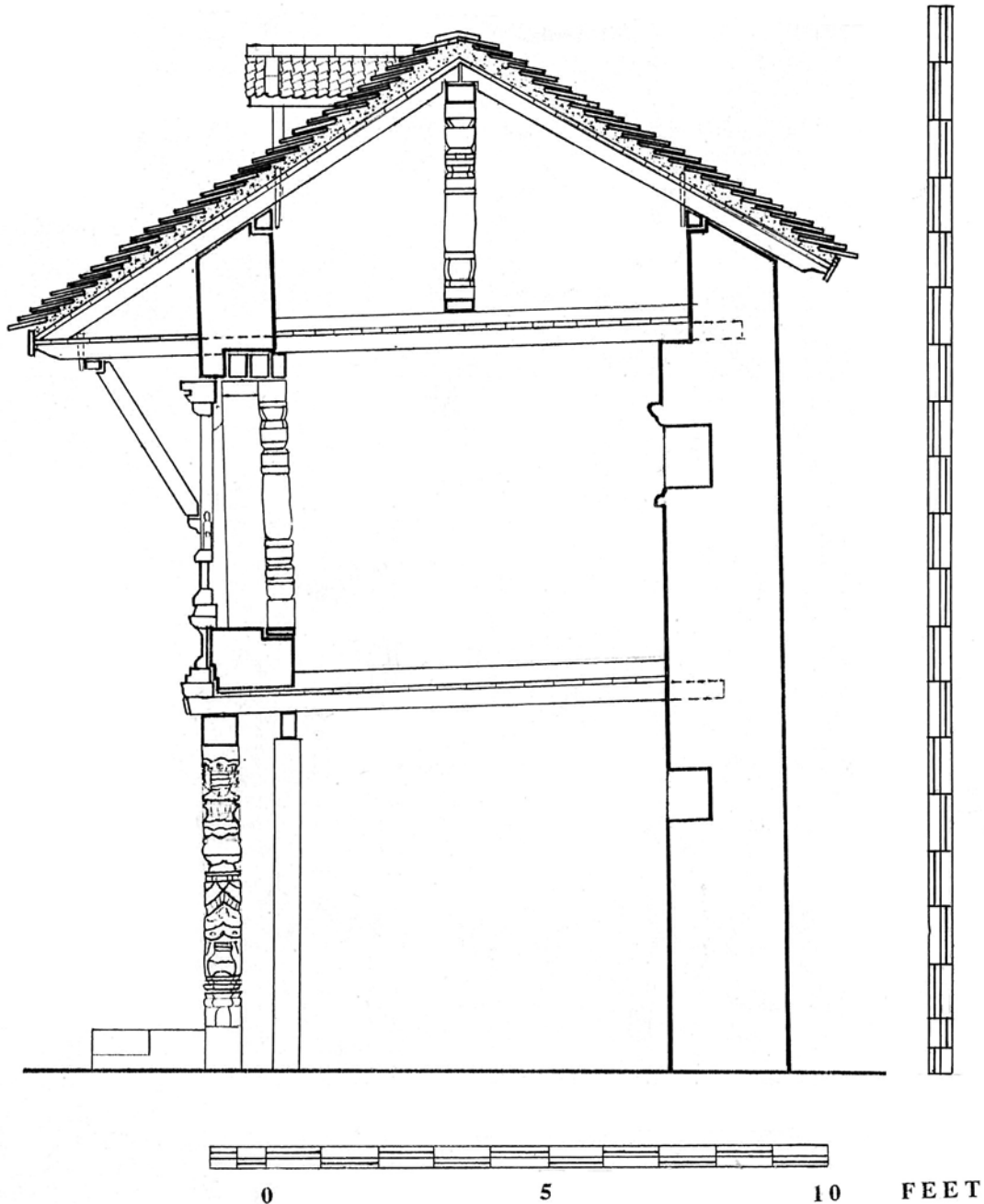

**AYAGUTHI SATTAL**  
**SOUTH-NORTH SECTION: EXISTING CONDITIONS**

KATHMANDU VALLEY PRESERVATION TRUST  
 DRAWING BY SUSHIL RAJBHANDARI, OCTOBER 1994

### **Masonry construction**

Rear and east walls are built of common brick or *ma apa* laid in mud mortar: they appear to be 50-100 years old, perhaps rebuilt after 1934 earthquake. It is possible that at this time the rebuilding incorporated the niche figures and roof struts which do not appear to be original to the building. A post-earthquake and hasty rebuilding is also suggested by the thoughtless and irregular spacing of rafters, the variety of rafter and joist timber sizes and finishes, and the use of carved column fragments to support the ridge beam in the attic.

### **Masonry details**

At the bottom of the facade an layer of carved brick atypical for such residential types has been incorporated, also perhaps borrowed from other earthquake damaged buildings. The cornice between ground and first floors is of non-descript design characteristic of 34 earthquake reconstructions. The facade veneer brick of the principal facade (Newari: *daci apa*) are very finely finished, that is highly fired with a smooth lustrous red color, typical of bricks more than 100 years old. They therefore may be original to the building, elements included in later repairs and re-buildings.

The building plinth on the southern elevation has been lost, incorporated into the 1974 pavement of the square which is too high. The plinth is of recent age as it is constructed in common brick, i.e. without the characteristic stone and tiles of historical practice.

### **Shutters**

New timber panelled shutters at the ground floor in the open arcade are less than ten years old.



Below: Oldfield's view of Patan Darbar Square, southern end, showing the two story Lam Pati. In the distance another one story resthouse, now lost, is visible. Above: Sarasvati Pati, three buildings west of the Ayuguthi Sattal defining Patan Darbar Square. This building (rebuilt in 1989) mixes 17th c. pillars and post-1934 colonial patterns above. Opposite top: Sundhara Sattal (1700), Sundhara, a high style variation similar to constructions of the palace. Middle: *sattal* at Kwalkhu with fine Malla period pillars (18th century) and post-1934 earthquake superstructure. Bottom: *Sattal* at Uku Bahal (19th century, reconstructed 1990).

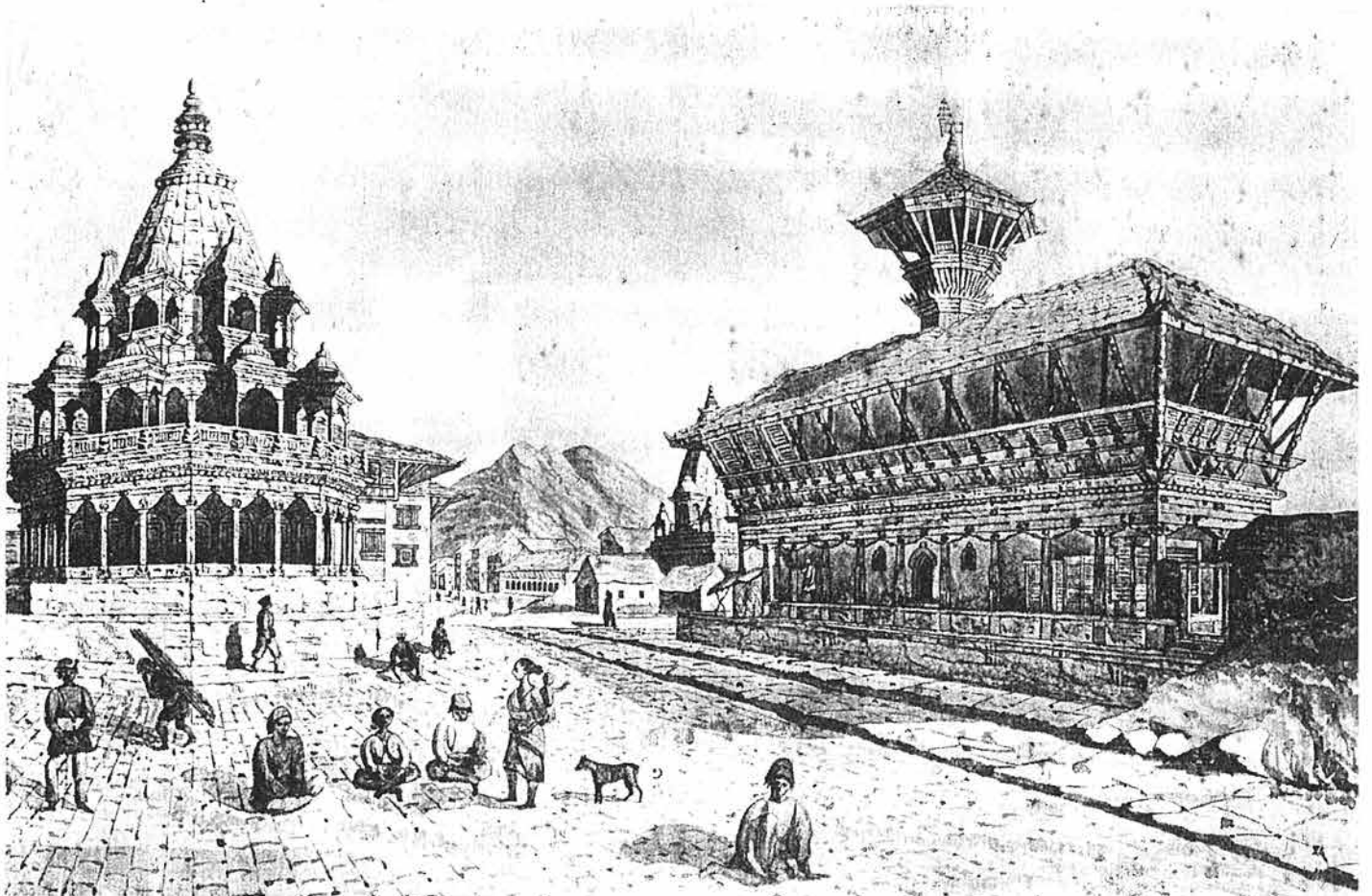





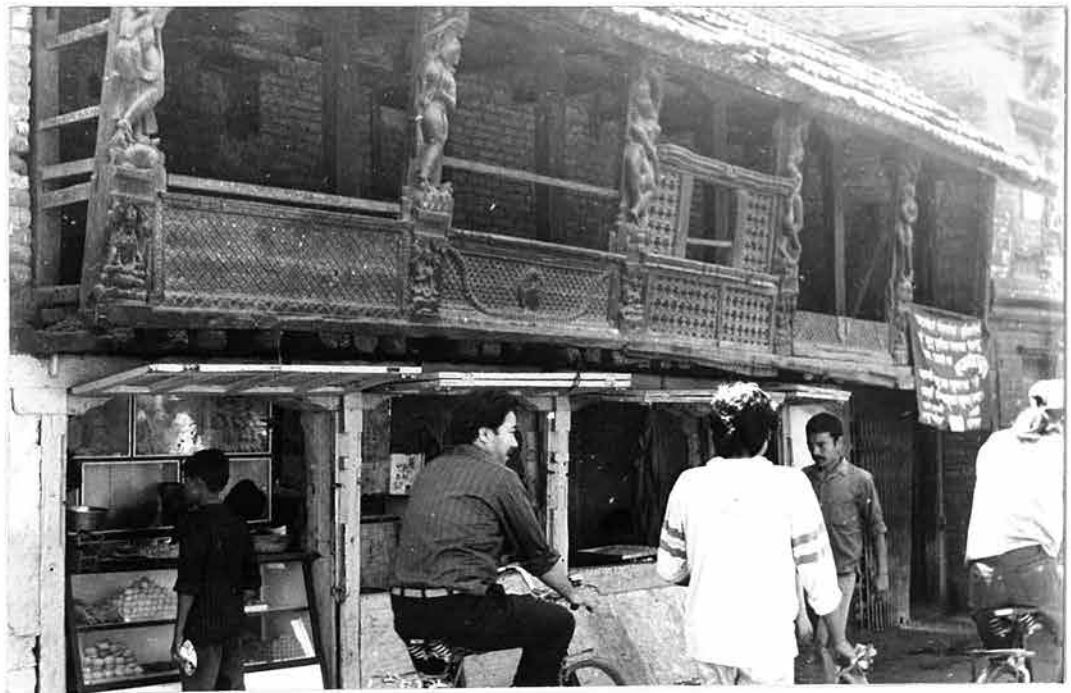

*Sattals* (Newari: *sattali*) of Kathmandu Valley: variations on a theme.

Opposite above left: 16th century Bhaila Dyah *sattal*, Taumadhi Square, Bhaktapur. Above right: 19th century two story *sattal* at Cikamugul, Kathmandu. Below: *sattal* at Bhimsenthan, Kathmandu.

Above: a royal *sattal* at Maru Tol, Kabindrapur Sattal 16th century. Below: Yetkha *sattal*, 15th century (?) with superb roof struts in the style of Ukubahal.

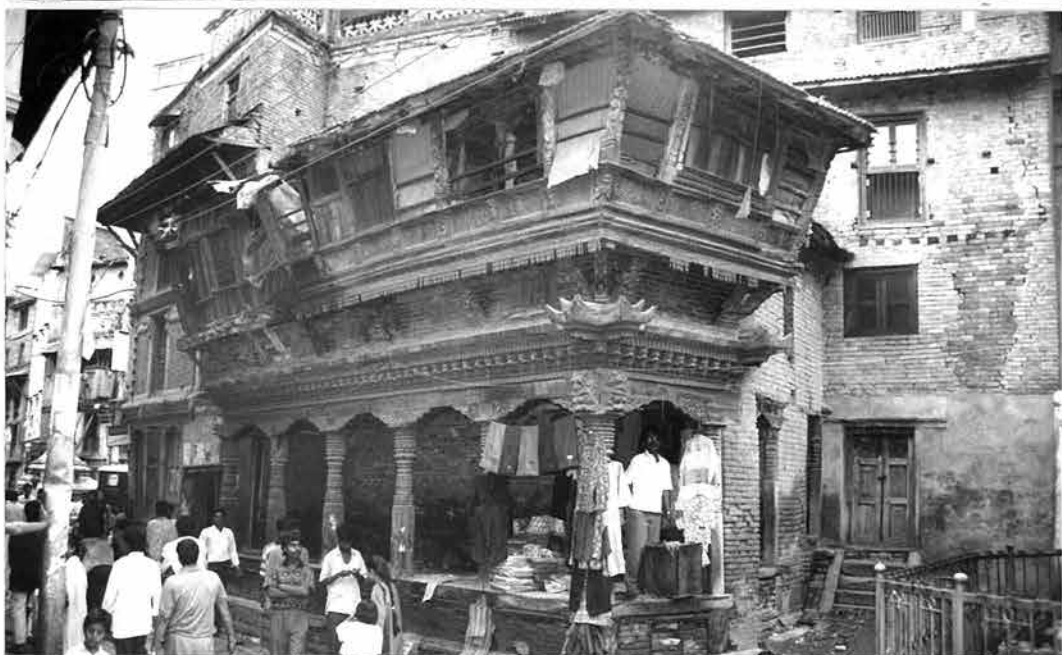



### 3.0 ARCHITECTURAL DESCRIPTION

*Sattals* or resthouses in the Newar cities of the Kathmandu Valley takes many forms. One can distinguish a *sattal* from a *pati* by its provision of a closed room of sorts, usually on an upper floor, where one can stay. Both *sattals* and *patis* can incorporate shrines.

Among *sattals* one can distinguish buildings which replicate the trabeate frame of the ground floor on two levels, "framework structures", and buildings whose masonry facades are more residential in character like the Ayuguthi Sattal. The more repetitive trabeate assemblies of the former are often used in royal constructions defining extensive lengths of the royal squares.

Typical of the more residential architectural features are the variety of window and opening types conjoined by axial symmetry. The larger symmetry of the facade has been affected by 1974 reconstruction (discussed in construction history above). In the Ayuguthi Sattal the upper bay window, of three small bays, surmounts a three bay arrangement of larger bays in the open arcade below. Smaller windows which flank the central bay window are typical of residential construction, particularly of the upperfloors, typically used for living quarters in a Newar house. The railing of these upper windows is called *kvatahdi* giving its name to this window type *kvasvahjyah* (literally a window to look down from). The arched opening of the central *san jhyah* bay window is called *gvahjyah* in Newari, literally round window.

The roof construction and strut assemblies as well as the bare interior arrangements are characteristic of traditional residential construction (see drawing p. 17). The single bay depth without a bearing wall under the ridge beam (Nepali: *ek nale*) characterizes only the smallest of residences, but is often employed for such diminutive resthouses.

*Sattals* (Newari: *sattah*) of Kathmandu Valley: variations on a theme.  
Opposite above left: 16th century Bhaila Dyah *sattal*, Taumadhi Square, Bhaktapur. Above right: 19th century two story *sattal* at Cikamugul, Kathmandu. Below: *sattal* at Bhimsenthan, Kathmandu.

### **Authenticity and aesthetics**

This building which incorporates elements from at least several other buildings and periods demonstrates both the stylistic continuity of the local building tradition and the builder's art, his ability to compose in an aesthetic way using various historical fragments.

### **3.1 TRADITIONAL BUILDING TECHNIQUES.**

The traditional construction of the *sattal* and construction in general employs bearing brick walls laid in yellow clay mortar (Newari-*mhasuca*) together with a secondary timber frame construction in which wall plates and rafters are connected by timber pegs and lapped joinery.

The brick wall construction consists of three layers with very few cross bonds: an outer facade brick (Newari-*daciapa*), one course thick; an inner bearing wall of common fired brick (Newari-*ma apa*) two layers thick; and middle fill of brick fragments (Newari-*dutha apa*). The characteristic facade veneer brick tapers in section away from the facade to allow hairline joints on the face with additional mortar behind.

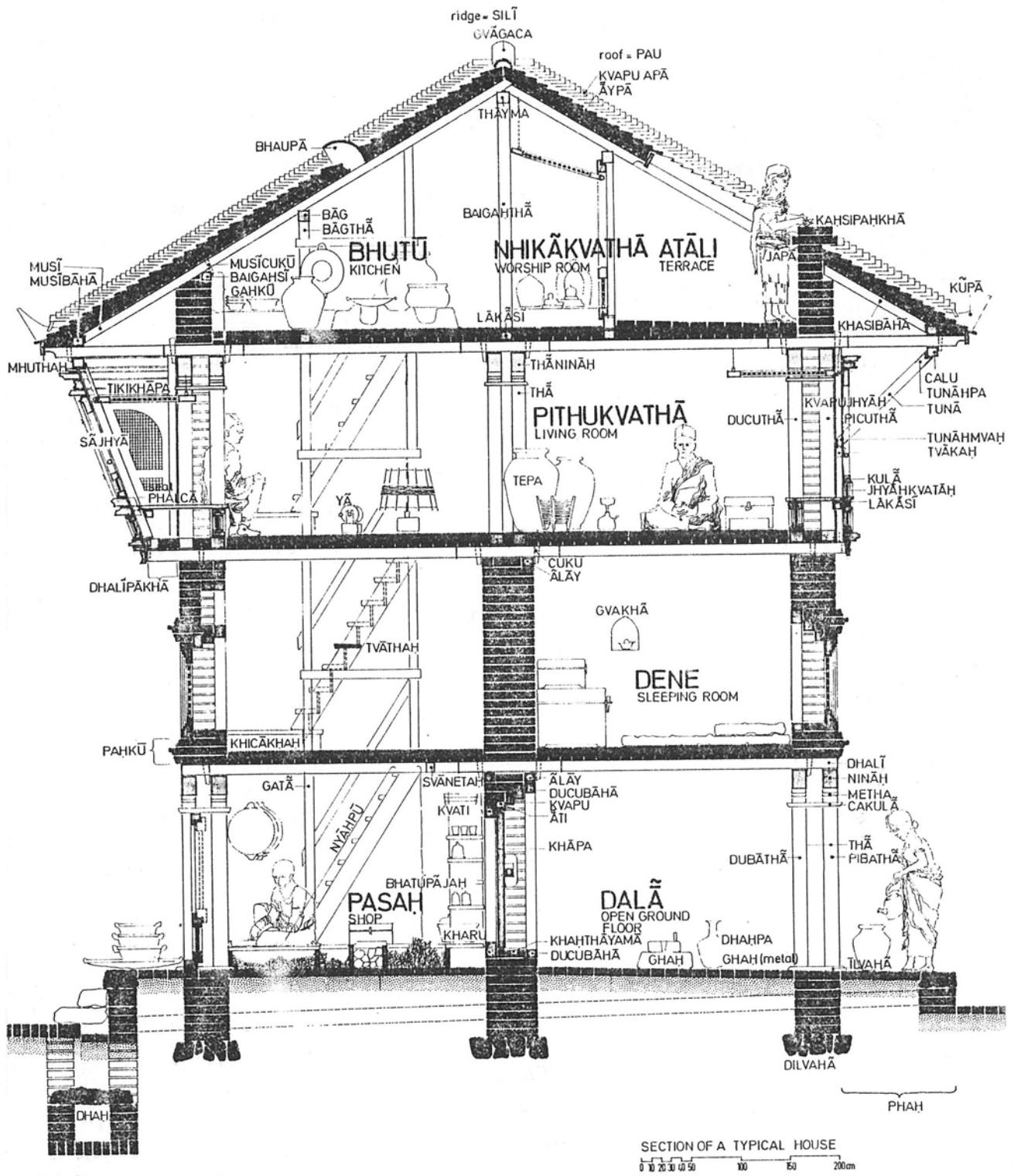

Annotated detail roof and wall section of Ayuguthi Sattal, local material names from Gutschow: *Newar Towns and Buildings* (p. 156).

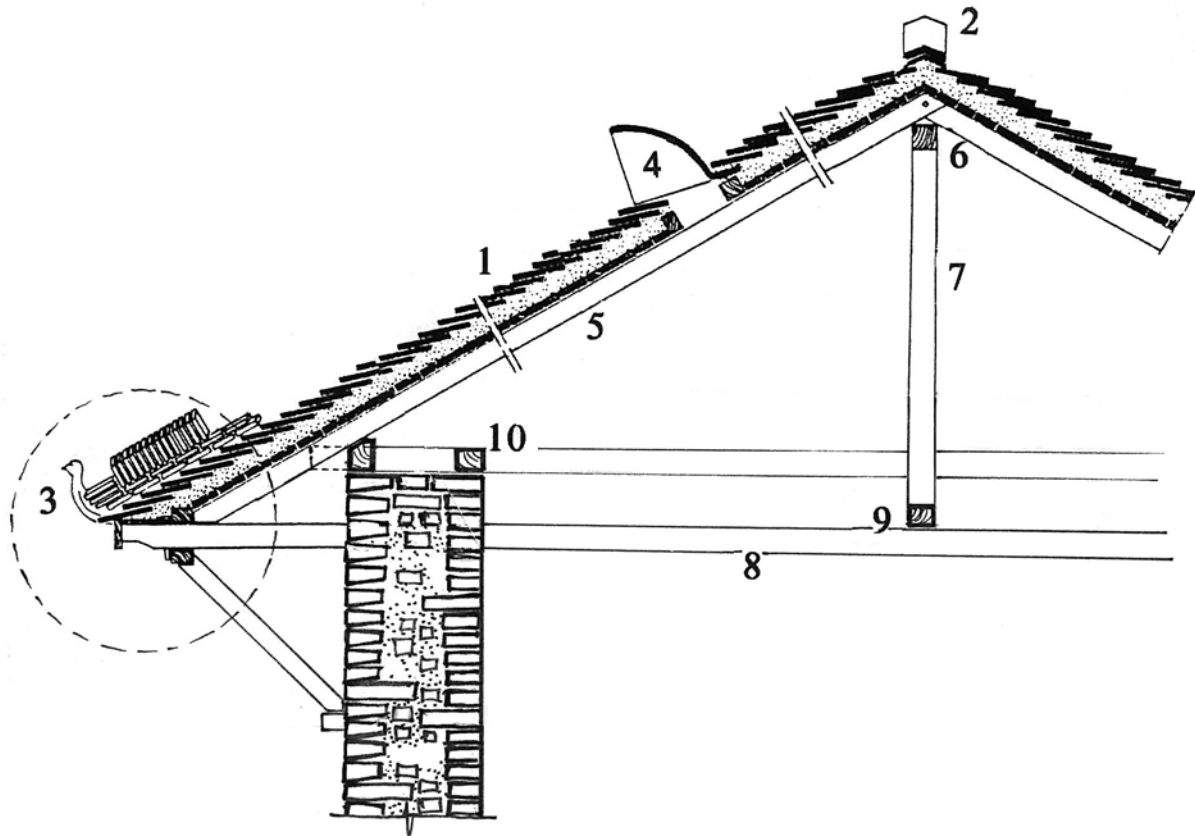

DETAIL OF A TYPICAL ROOF AND WALL SECTION, SIMILAR TO AYUGUTHI SATTAL. TRADITIONAL ROOF COVER SHOWS *JHINGATI* ON MUD BED ABOVE PLANKING AND COMPOSITE WALL LAYERS OF OUTER VENEER BRICK, MIDDLE FILL AND INTERIOR BEARING WALL.

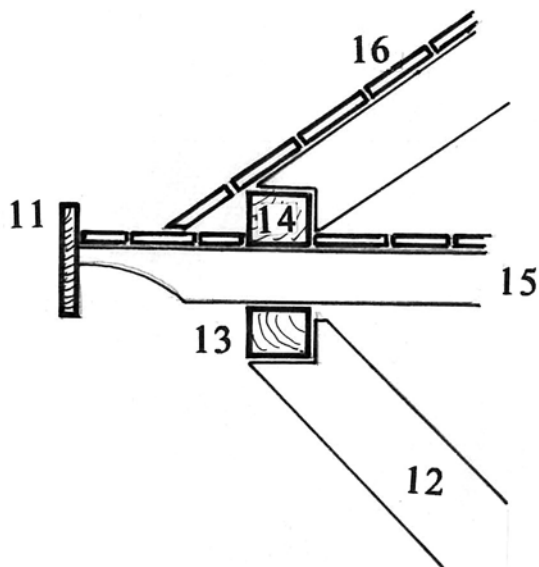

- |                                 |                         |
|---------------------------------|-------------------------|
| 01. Roof tile                   | - <i>aypa</i>           |
| 02. Ridge tile                  | - <i>kapuapa</i>        |
| 03. Corner tile                 | - <i>kupa</i>           |
| 04. Cat hole tile               | - ( <i>bhaupvahpa</i> ) |
| 05. Rafter                      | - <i>musi</i>           |
| 06. Ridge beam                  | - <i>thayma</i>         |
| 07. King post                   | - <i>baigahtha</i>      |
| 08. Joist                       | - <i>dhali</i>          |
| 09. Base plate of the king post | - <i>lakasi</i>         |
| 10. Wall plate                  | - <i>nas</i>            |
| 11. Eaves                       | - <i>mhutah</i>         |
| 12. Strut                       | - <i>tunah</i>          |
| 13. Purlin                      | - <i>chalu</i>          |
| 14. Purlin                      | - <i>musibaha</i>       |
| 15. Eaves joist                 | - <i>dali</i>           |
| 16. Planking                    | - <i>sipu</i>           |

**Detail roof and wall section.**

Traditional roof cover shows *jhingati* on mud bed above planking and composite wall layers of outer veneer brick, middle fill and interior bearing wall.

The *daciapa* of more than 100 years ago is an extremely well-fired and dense brick with a finished smooth surface on only one side, excepting corner pieces, which are finished on two sides. The finishing is achieved through the application of a red clay slurry (Newari-*laca*) applied after sundrying and before firing. Laid tightly, the lustrous brown crimson *daci apa* provides a fine and smooth background for the sculptural effects of the woodcarvings.

The foundation structure of Ayuguthi Sattal has not been excavated. One can imagine that it is comparable to other buildings of the period constructed in stone laid again in yellow clay. The plinth now lost would have probably been built up in fill defined by the foundation walls and outer brick walls faced with *daci apa* and stone aprons.

The timber structure of Ayuguthi Sattal conforms to the traditional formula: closely spaced rafters (varying center-to-center dimensions 9" to 16") laid on the flat are tied to wall plates and purlins with timber pegs. Additional short members project like joists (Newari: *dhali*) at eavesboard level to close the underside of the eaves, this is one of two variants for eaves construction called *dhalipakha*.<sup>2</sup> The other is called of the to form the "hanging eaves" (Newari-*kvachupakha*).

Sal timber (*shorea robusta*) a local teak is traditionally employed for most structural and virtually all decorative timbers. Pine was used in many 19th and early 20th century reconstructions, but may also have been employed in the Malla period.<sup>3</sup> One hundred percent of the interior structural timber of the Ayuguthi Sattal is in pine.

The integrity of the timber structure, like many examples in Nepal, has suffered in the course of repairs and reconstructions. We do not know how precise the joinery of the original construction was, but later work has been characterized by ill-fitting mortise and tenon joints, irregular spacing and sizing of members, over-cut lap joints, and improper placement of timber pegs.

---

<sup>2</sup> Gutschow, N. *Newar Towns and Buildings*, p. 160.

<sup>3</sup> This point is further discussed in Theophile and Ranjitkar. *ICOMOS International Wood Symposium 8th Int'l Symposium*, pp.86-7.

### 3.2 ICONOGRAPHY/CARVINGS

The *San jhya* is notable for their Buddhist motifs of *kalash* (water vessel) and panels of large lotus flowers. Each of the *san jhyah* panels renders the *kalash* motif slightly differently. The interlace of the surrounding foliage shows the influence of Moghul designs from Lucknow characteristic from the late 18th century onward. The lower skirting of the *san jhyah* is particularly robust with bell motifs below, waves, surmounted by timber *kula* (the typical cornice motif with upturned ends) surmounted by a dentil-like motif.

The capitals (Newari: *meth*) are rare and particularly fine for their inscribed water vessels or *kalash*, echoing those of the columns and the *san jhyah* panels.

The flanking upper floor windows or *kvasvahjyah*, like the ground floor doors are simply rendered with only a formulaic band of lotus petals. The window railing post, with its tulip like knob, is more Moghul and onion -like than traditional and more squat Newar examples.

The roof struts are not roof struts but rather re-used vertical members of a leaning bay window (Newari: *san jhyah*). Their Buddhist themes root them in Patan where they may have been rescued from a Buddhist quadrangle (Newari: *bahal/bahi*) destroyed in a great earthquake in 1833<sup>4</sup>.

The niche figures are probably not original to the building and certainly not carved for the crude niches of this century which house them. The figures include Siva, Visnu, and Bhairav and stylistically appear to be atleast 300 years old.



<sup>4</sup> This earthquake is mentioned in Wright's *History of Nepal*. Current research by the author suggests that many more buildings were rebuilt at this time than previously suspected, including such venerable structures as Pasupatinath and Panauti's Indresvara Mahadeva.



Opposite: detail of *san jhyah* central bay showing *kalash* and floral interlace. Above: detail of *san jhyah* left bay with *kalash* panel above and large scale lotus leaf pattern. in lower panel. Below: *san jhyah*, fall 1993.





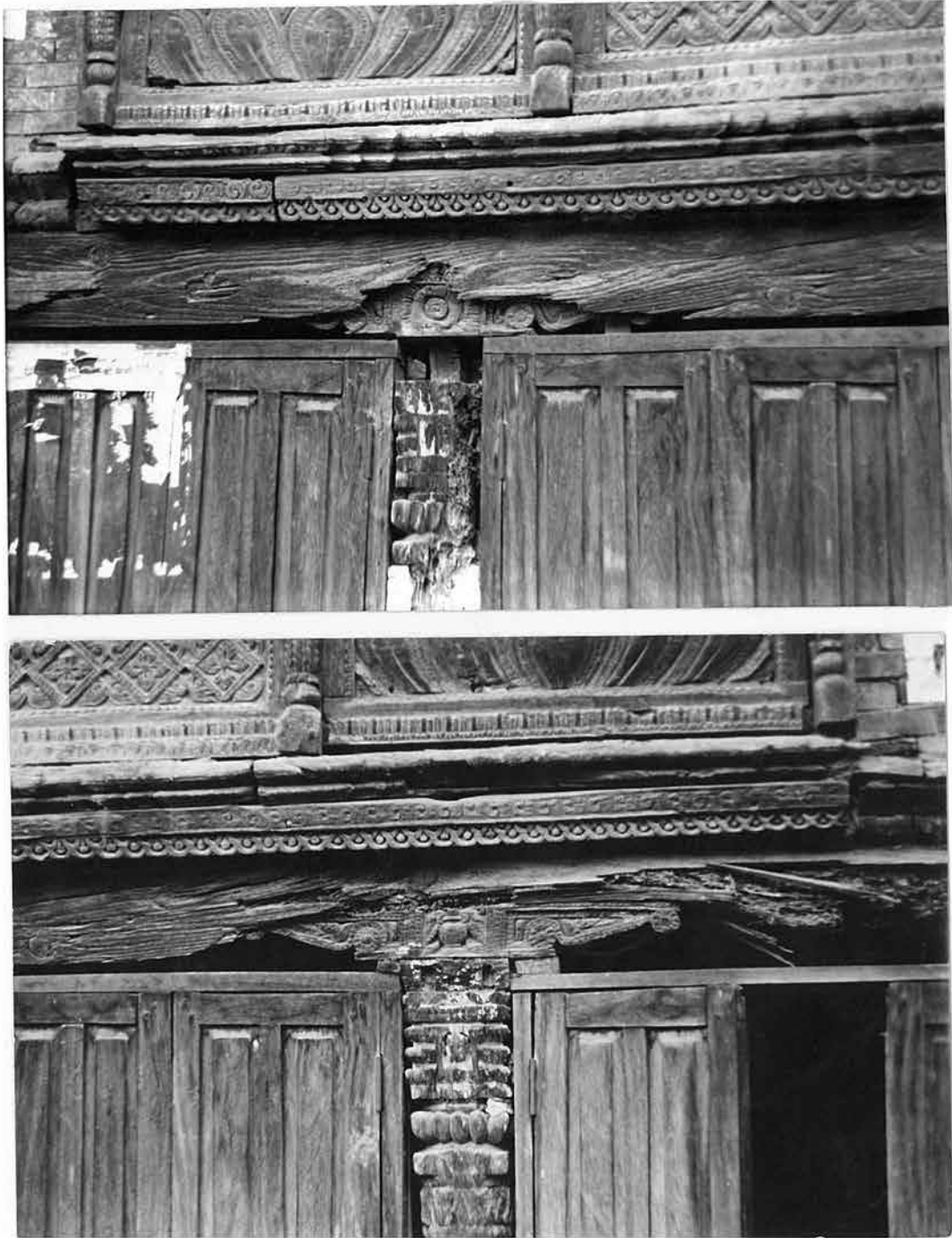

Column capitals ( left central above; right central below ). The details in the middle carved panel of each capital (Newari: *metli*) varies: above lotus flower, below water vessel or *kalash*. Opposite: end columns are more heavily damaged and decorative details are indeterminable.



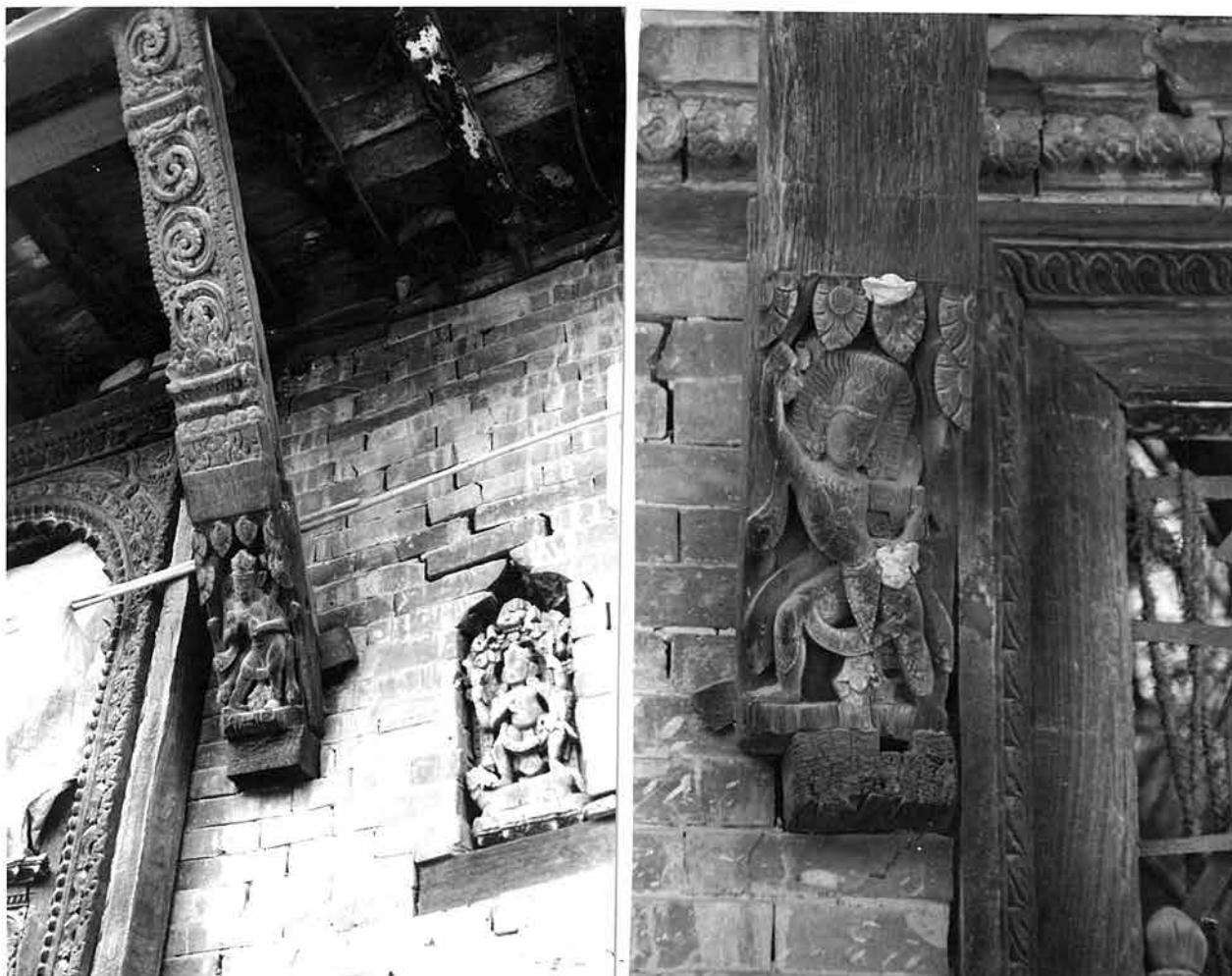

Roof struts (Newari: *tunah*). Five existing carved struts come from a leaning bay window (Newari: *san jhyah*) as demonstrated by tenons visible on the sides of each piece and the format, which would be unusual for a typical roof strut. The struts are divided into two registers with varying figures below and repetitive wave motifs above. Struts numbered left to right 1-5). Opposite upper left: strut#1 with Bhairav figure; upper right: strut #2 another pose of Bhairav; opposite lower left: strut # 3 Visnu. This page left: strut #4 Siva and right #5, Siva (?).

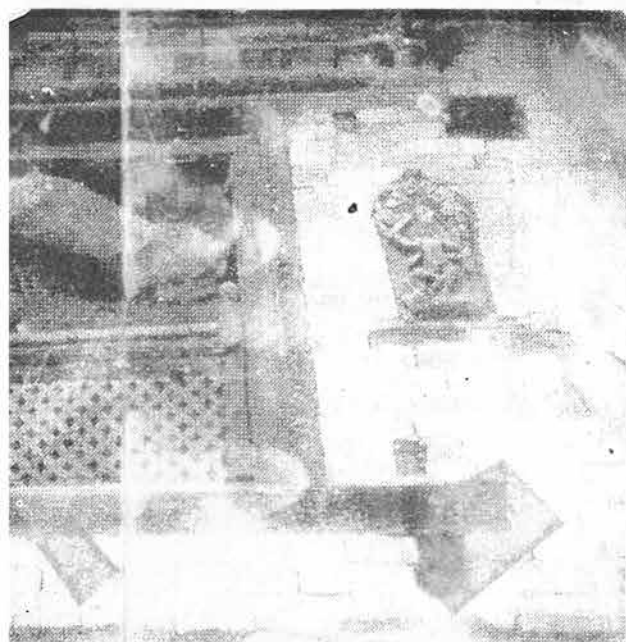
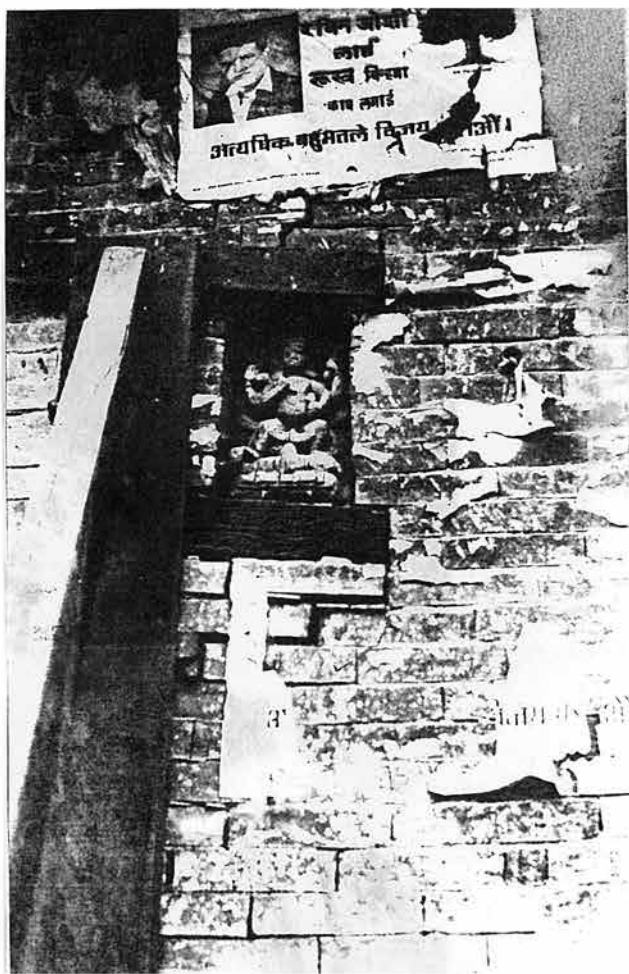

**NICHE FIGURES:**  
 Above left: Vishnu ; above right Siva(2nd and 4th niches from left). Two additional struts depicting Bhairav are not possible to photograph because of temporary shoring. These figures do not appear to be original to the simple niches, although it is possible that they are original to the building.

## 4.0 EXISTING CONDITIONS

### Summary

Two major problems threaten the structure: the damaged roof on the eastern third of the building has allowed water penetration into the interior timber frame and principal facade for the last 15 years. The second problem is advanced termite infestation of the structural timber, in particular, the pillars and beam of the ground floor's central pillared opening (Newari: *dalan*) and ground floor ceiling joists.

### 4.01 Foundation and wall structure

There are no signs of foundation settlement in this or adjacent structures. Trial excavation of the foundation is now possible and will be undertaken shortly.

#### Principal facade

The entire facade to the right of ground floor *dalan* has deteriorated over the last seven years, in the last year the veneer brick or *daci apa* has fallen out. Photos of 1988 show a stepping crack travelling 28 courses up, just touching the right end of the *dalan's* lintel beam. The crack appears not to have been larger than one half inch, but water penetration from the damaged roof above caused the individual layers of the wall to separate, the outer veneer splaying out. This is a typical problem in the traditional buildings of the Kathmandu Valley.

Extensive damage to the *dalan* beam by termites has put further stresses on the wall: the pine timber lintel, completely denatured by the insects, has allowed the upper floor joists and facade to settle six inches.

The left half of the masonry facade is in fair condition with no large cracks or signs of rising ground dampness.

#### Side and rear walls

Rising ground dampness has caused minor damage along the back and side walls to the masonry structure including spalling of some 80 bricks up to a 10 course height. Interior cement plaster has allowed the dampness to travel higher than the typical four feet, the timber joists are consequently all rotten at resting wall locations (discussed under timber 4.04 below).

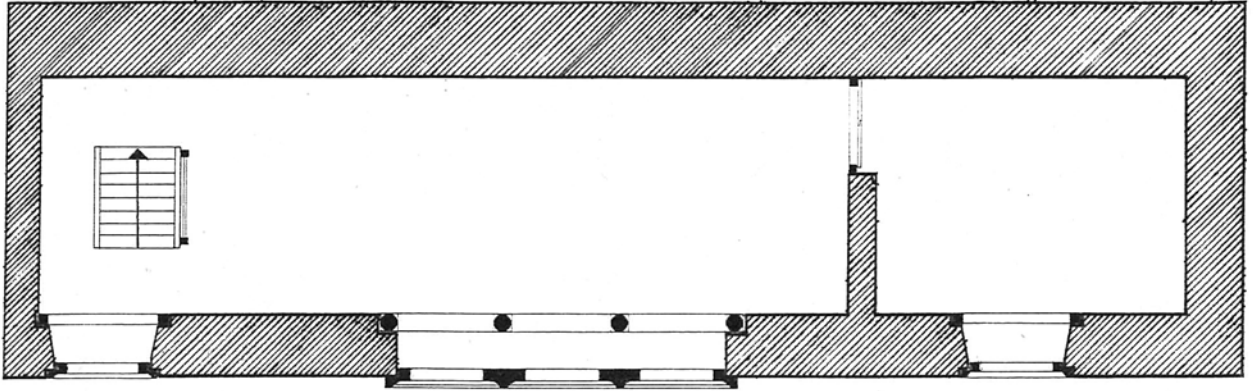

**AYUGUTHI SATTAL**

FIRST FLOOR PLAN: EXISTING CONDITION

KATHMANDU VALLEY PRESERVATION TRUST  
DRAWING BY SUSHIL RAJBHANDARI, OCTOBER 1994

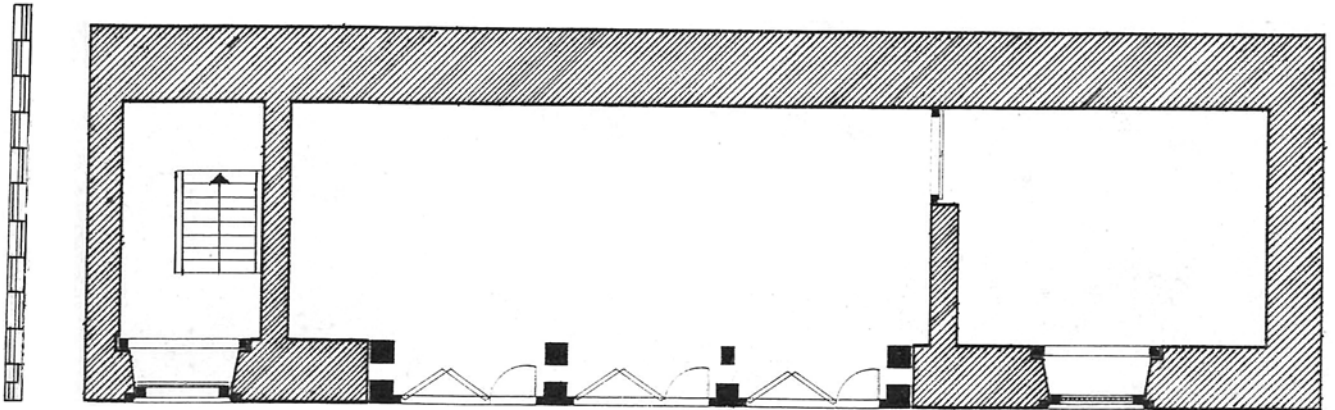

**AYUGUTHI SATTAL**

GROUND FLOOR PLAN: EXISTING CONDITION

KATHMANDU VALLEY PRESERVATION TRUST  
DRAWING BY SUSHIL RAJBHANDARI, OCTOBER 1994



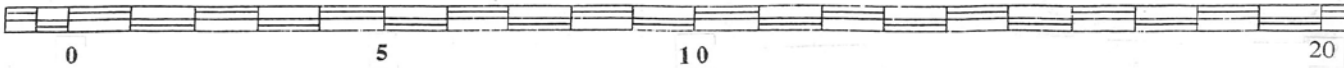

# AYUGUTHI SATTAL

PRINCIPAL ELEVATION: EXISTING CONDITION

KATHMANDU VALLEY PRESERVATION TR

DRAWING BY SUSHIL RAJBHANDARI, OCTOBER 1994



## EXISTING CONDITIONS

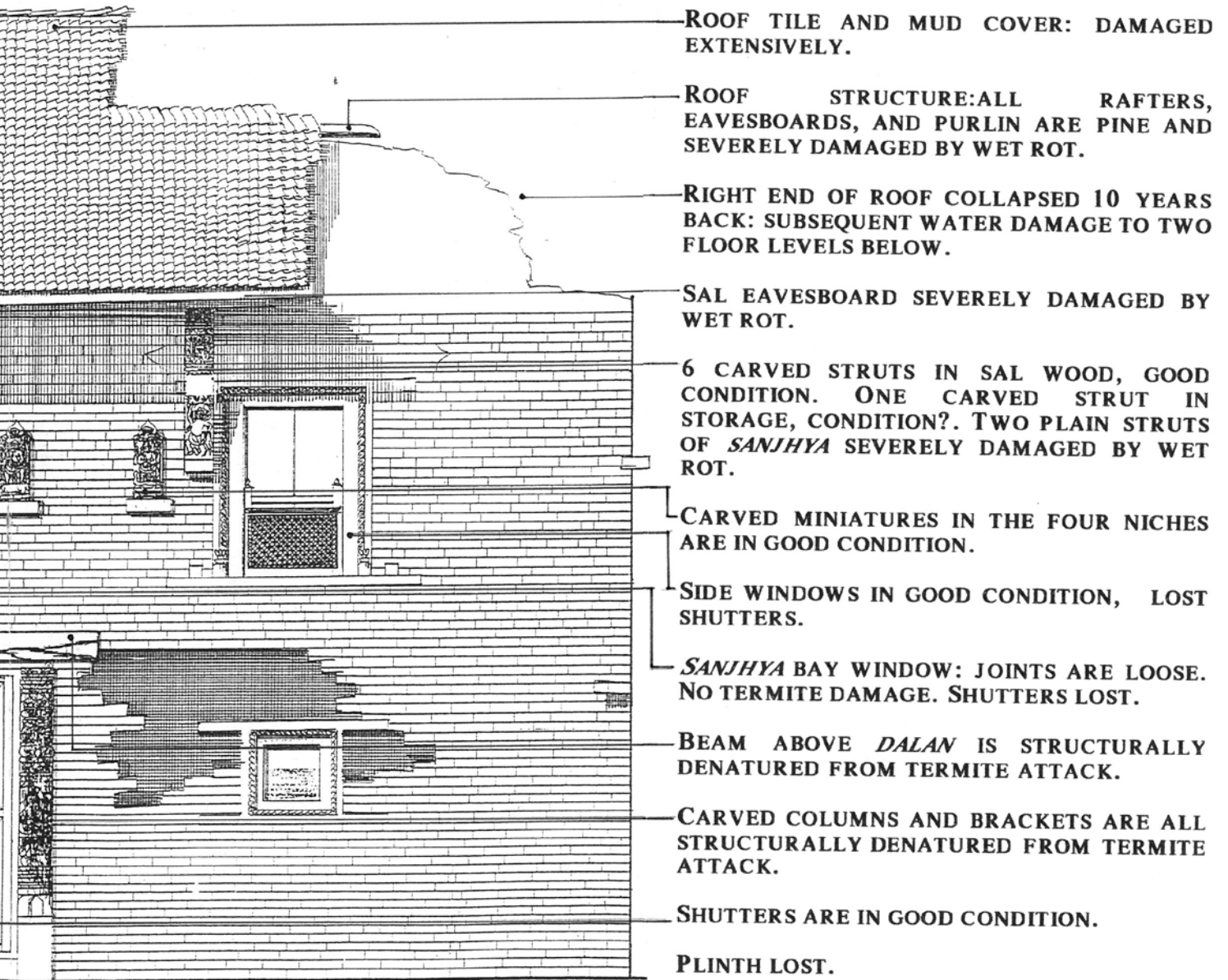

**EXISTING CONDITIONS**

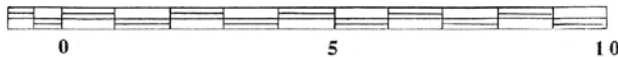
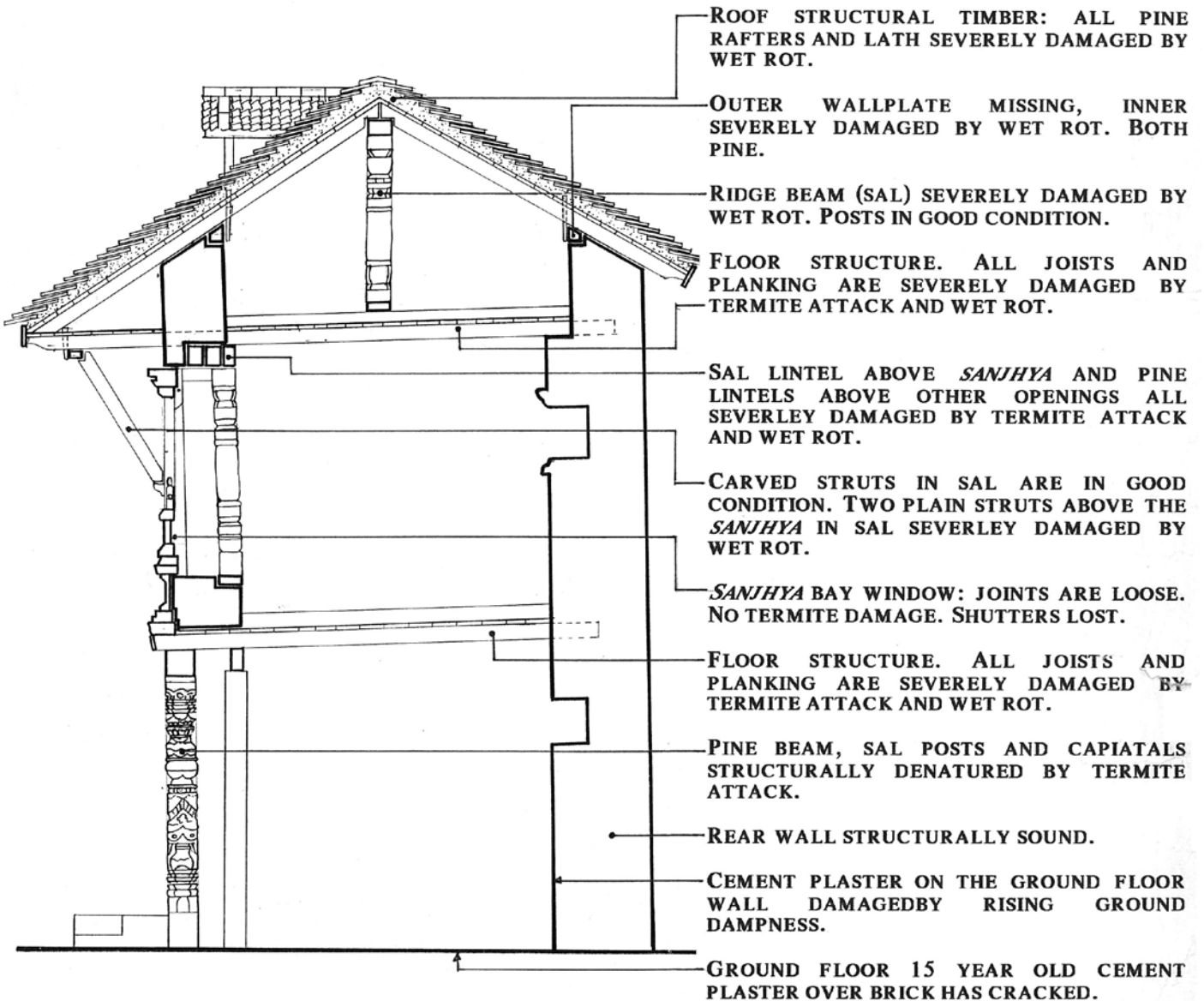

**AYUGUTHI SATTAL**

SOUTH-NORTH SECTION: EXISTING CONDITION

**KATHMANDU VALLEY PRESERVATION TRUST**

DRAWING BY SUSHIL RAJBHANDARI, OCTOBER 1994

#### **4.02 Wall fabric**

As described above, *dacia apa* veneer brick is lost on the right third of the building.

Rear and side facades retain common brick, *ma apa*, in fair condition laid in yellow mud from the 1974 renovations and shortening of the building.

Interior cement plaster on interior ground floor by current occupant 5-10 years old has cracked due to rising ground dampness.

The plinth of the building in brick survives only in front of the left two-thirds of the facade, although it has been integrated into a larger paved level of the square dating from the 1974 Ganesh temple renovations. This plinth in *ma apa* does not appear to be more than 30 year old: typical older traditional solutions would be constructed in a combination of brick, stone, and terra cotta tiles (Newari: *cika apa*).

#### **4.03 Walls: timber elements /openings**

##### **Windows, doors**

Structural frames of the upper story windows including two flanking and central bay window, *san jhya* are all in fair condition except for some noticeable loosening of the joints in the *san jhya*. There are no signs of termite attack. All openings of the upper floor are missing their shutters (Newari : *kapha* ) and are covered with makeshift materials. One interior door survives with shutters in fair condition. The ground floor door alone retains its historical shutters, both frame and shutters in good condition.

The right hand ground floor window has been stored by the occupant after collapse of the veneer wall; condition was fair before storage.

##### ***Dalan***

All four historical oversized and carved timber posts in sal wood are completely structurally denatured by drywood termite infestation. This infestation was diagnosed by visiting expert Sir Bernard Feilden (based on the pest's visible mud tracks). The column capitals (Newari: *meth*) are damaged to varying degrees by the termite infestation as well, the outer of four capitals severely denatured, the central two capitals appear to have only superficial damage.

The upper lintel of the *dalan* is a pine member (section 7"x6") which is also structurally denatured by termites, having collapsed into itself from the load of the walls above. This has caused settlement of the central wall ranging from 4-6".



Above, the two upper story windows left and right are in good condition missing only their shutters and small portions of lattice. There are no signs of termite damage. Below the roofless southeast corner of the building with latticed window. This window has since fallen out due to wall damage and is in storage, condition unknown .

Opposite: the central trabeate opening (Newari: *dala*) is heavily damaged by termites, the outer columns slightly more advanced in their decay than the central pair. Below: the door is in good condition, although interior lintels are termite damaged. Below left: dormered opening in pine is heavily damaged by water.



The pine shutters of this *dalan* are of recent and unobtrusive design approximately ten years old.

Four decorative carvings in upper story niches are in good condition showing no signs of termite infestation.

There are no openings on the rear and side walls of the building.

#### **4.04 Roof and floor structure**

##### **Summary**

**The eastern quarter of the roof collapsed 10-15 years ago. Roof configuration is not original to the building (as discussed in construction history above). All timber rafters are heavily damaged by water, rotten except for very small areas. Two levels of floor joists--like the rafter configuration--are carelessly installed possible from post-1934 earthquake repairs. Both levels of joists are heavily damaged in all but a few locations, the lower level primarily from termites and water, the upper primarily from water.**

##### **Rafters**

The roof was rebuilt in 1974 during the renovation to the adjacent Ganesh Temple incorporating older timbers of random sizes and finishes. The quality of joinery is particularly poor : overcut joints occur on 60% of the rafters. The two attic posts supporting the ridge beam are carved pillars of different designs and size, incorporated from two different buildings. Rafters are irregular and of varying finishes; all are pine. Their spacing is fairly regular (averaging 1'0" center to center). These rafters which include many scrap pieces and unhewn timbers are all rotten from the continued dampness from roof leaks. All lath above the rafters is also rotten, accelerating the damage to the rafters by holding the dampness.

Eavesboard on front elevation is of sal and is rotten.

##### **Joists at two levels**

Pine sizes varying from 4"x3" to 5"x4". Spacing 1'0" on center. Less than 100 years old with adze (Newari: *basila*) finishing. All are termite damaged on the lower level; where they rest on the wall there is considerable wet rot as well. There are no new members or recent repairs. The upper floor joists are uniformly damaged from roof leaks, severely deteriorated except for isolated locations. The floor structures have been shored up three years ago by KVPT to prevent collapse.



Collapsed roof structure at southeast corner of the building.

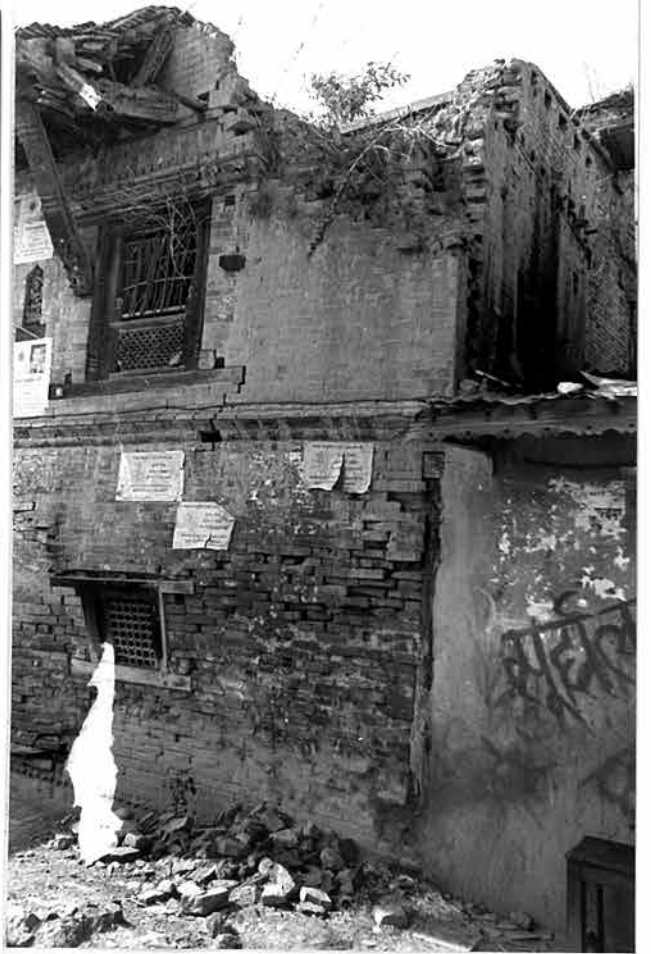

### Roof struts

Seven carved struts (of nine total) are all of sal and are in good condition. There are no signs of termite attack. Two of these struts (from right end of building) are in storage. The two uncarved struts above the *san jhyah* are sal and heavily damaged by wet rot.

### 4.05 Roof cover

The traditional timber lath above the rafters is completely structurally denatured from wet rot. The terra cotta roof tiles (Nepali: *jhingati*) where intact are in excellent condition with no signs of moss or grass growing between the cracks. Approximately 60% of the roof tiles remain unbroken on the roof.

The stacking tiles (Newari: *nyahkuca* literally five-corners) used at ridgeline and at gable ends are largely missing, replaced by bricks in some places.

Small terra cotta roof vents (Newari: *bhau puah*, literally cat holes) appear not to be damaged.

### 4.06 Interior

Cement plaster is found on the ground floor walls and floor, applied over the traditional tiles (Newari: *cika apa*) typically laid in mud. Ground floor plaster cement cracked and rough. Mud floors between 4 and 8 inches thick are found on the two upper levels. Traditional mud wall plaster on the upper two levels is extensively damaged and/or chipped off from water damage.



## **5.0 Recommendations for Repair**

### **Introduction: summary of critical project conservation issues**

- \* **Identification of appropriate restoration versus preservation project goals**
- \* **Strategies to repair the building *in situ*, i.e. with minimum dismantling and maximize retention of historical fabric**
- \* **Introduction of seismic retrofitting and dampproof course in an unobtrusive and efficient manner.**
- \* **Termite treatment**

### **Restoration versus preservation**

Analysis of the building demonstrates that the facade results from the combination of elements from several different buildings of different periods, reconstitutions. The architectonic quality of the facade is not inconsiderable, however, and bespeaks the formal continuity of the architectural vocabulary and the compositional abilities of the craftsmen--even when rebuilding in a hasty way after an earthquake, as may have been the case with the Ayuguthi Sattal.

Thus, the proposed conservation of the Ayuguthi Sattal as it stands (and without the reconstruction of the lost west end) is a clear demonstration of the preserve rather than restore approach, a critical demonstration project for Nepal.

Only in the case of the Ayuguthi Sattal plinth will an attempt be made to *recapture* something that has been lost, as all of the pavement is careless and of recent date. Plinth reconstruction in traditional materials is also possible to achieve to a high standard, as demonstrated by the Uma Maheswar project of the Trust in 1992.

### ***In situ* repairs**

Not unrelated to the preserve -rather-than-restore principle is the design of *in situ* repairs. They are particularly critical in such highly visible and internationally supported projects to set an important precedent: general practice in Nepal among international and local projects almost always errs on the side of reconstruction. In the case of Ayuguthi Sattal the effort to maintain the extremely rich historical patina of this building is particularly justified. To achieve such conservative work involves detailed design of construction steps, i.e. what is done or replaced in what order and with what temporary shoring, etc. This construction and repair process will take considerably more time and supervision than rebuilding. As in all Trust projects, the project architects act as contractor and conservation consultant to

guarantee high quality results. Lastly, an architect must be on the site almost all the time to prevent well-intentioned, but detrimental dismantling by craftsmen and laborers.

Of prime importance to maintain the patina of the facade will be the maintenance of the facade to the left of the central dalan, guaranteeing the maintenance of brick course heights and rippling surface. The collapsed right portion will be dismantled and rebuilt using the original bricks. Where insufficient, historical bricks of identical size and similar color will be scouted to avoid the clash of new and old brick. (To date no new brick production has been able to approach the old in terms of brick hardness, finish, color or lustre.)

Although the timber interior structure must be completely replaced, to maintain authenticity the work will be accomplished without full dismantling, but rather by piece by piece repair or replacement. In this manner the historical configuration can be maintained.

## **5.01 Structural: general issues and seismic retrofitting**

### **Introduction**

Recent projects by the Trust have built experience in a variety of approaches to seismic retrofitting. These include concealed reinforced concrete and timber ring beams, development of stiff plates through rebuilt timber floor structure, and the insertion of a "back-up" interior timber frame, a permanent interior scaffolding designed to carry upper floor and tower loads in the event of wall failure.

These examples represent different levels of interventions in the historic structure--from reinforcement of historical timber structure to insertions of new structural elements using modern materials. There is a great deal of controversy surrounding the appropriate techniques to achieve seismic retrofitting at this time in Nepal.

Given the small scale and structural configuration of this building a conservative approach is possible, that is, the strengthening of the historical structure with traditional materials.

Given the seismic activity of Nepal, any restoration project must consider both the reinforcement of existing structure and the introduction of new structure/components to help historical buildings withstand earthquakes. Key characteristics of Ayuguthi Sattal's traditional construction which affect earthquake performance can be summarized:

- \*lack of through-wall connections and corner jointing reduces wall ability to act together as cellular unit, a general strategy for reinforcement
- \*shoddy carpentry repairs of the last 60 years and water damage are structurally unsound putting the building at great risk
- \*the mud mortar construction of the walls is generally positive with respect to earthquakes, allowing the building to absorb shock without damaging the bricks
- \*the small proportion of openings to the wall area is positive; the lack of openings on three sides, although introducing asymmetry with the principal facade is reinforcing.
- \*the diminutive size of the building in section and length, together with a relatively low centre of gravity are positive with respect to earthquake performance.

Given the very small scale of this structure--especially in comparison with recent Trust work with structural engineers on larger and complex multi-story buildings, a conservative reinforcement scheme which strengthens traditional structure rather

than introducing major interventions is proposed. Given the low center of gravity of the building, a scheme focusing on lateral strengthening through ring beam and stiff floor plate is proposed. Obtrusive or intrusive new vertical structure is not considered necessary. Moreover, as the timber structure must be rebuilt, to such a great extent, there is an clear opportunity to detail the timber structure to improve earthquake performance.

The components of this proposal to improve the traditional structure include:

\*connections between rafters and wall plates: in traditional structures the rafters are often not notched to the wall plates, held only by timber pegs. Concealed stainless steel bolting of every third rafter together with notching of each rafter greatly improves the rigidity of the roof frame-wall plate connections, a general strategy for seismic reinforcement.

\*wall plate-wall plate connections. The traditional configuration of double wall plates (one inner, one outer) can be developed as a timber ring beam of sorts by careful sizing and joinery at the corners. At the Ayuguthi Sattal this traditional double wall plate was lost during shoddy repairs, but can easily be reinstated. Further strengthening will be provided by concealed iron angles, coated with anti-corrosive paint. The project team executed similar improvements at Uma Maheswar Temple under the technical guidance of Engineer Manohar Rajbhandari.

\*Wall reinforcement--in the portions where the front facade will be rebuilt, stranded stainless steel wire<sup>1</sup> will be introduced to improve lateral and through wall connections of the wall. All work will be done using mud mortar, a positive material for its shock absorbent character. Additionally, the veneer brick bonding with inner layers can be improved by increasing the number of headers.

\*The foundations will be excavated to determine if any seismic-related improvements are necessary.

\*Lastly, it should be mentioned that timber planking is generally used in place of lath for repairs to historical buildings in applications above rafters and joists. This substitution of a different member is not commonly identified as a modern intervention, but dates to Hanuman Dhoka work under UNESCO in the 1970's. The planking has a longer life than the lathe, and in interior

---

<sup>1</sup> This wire has been kindly gifted to the Trust by Sir Bernard Feilden.

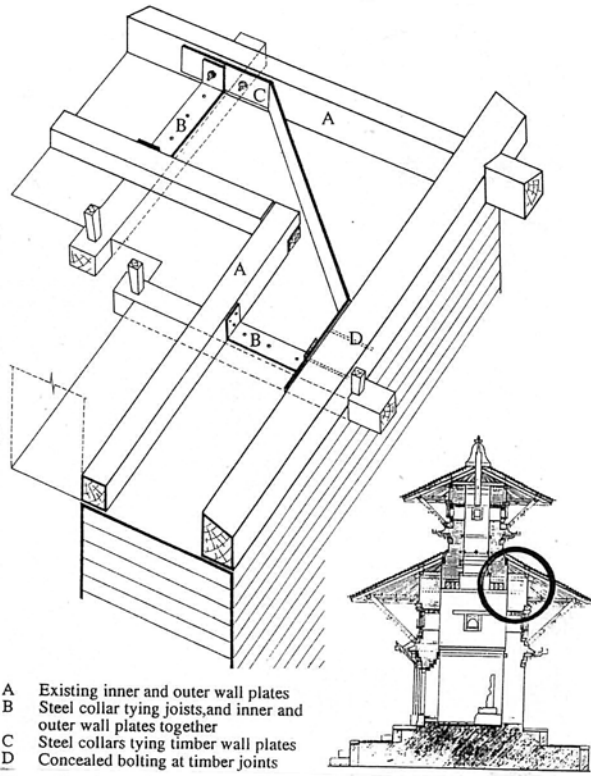

- A Existing inner and outer wall plates
- B Steel collar tying joists, and inner and outer wall plates together
- C Steel collars tying timber wall plates
- D Concealed bolting at timber joints

**Detail of timber ring beam and pagoda section.** 1992 reinforcement of Uma Maheswar Temple included development of the existing timber wall plates as a ring beam, as well as other reinforcements of the timber structure including concealed bolting of rafters to wall plates.

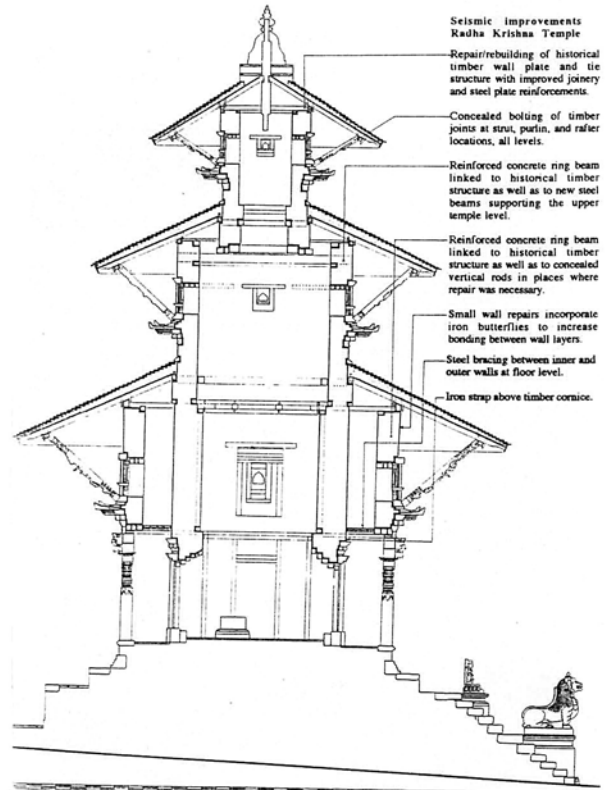

- Seismic improvements Radha Krishna Temple
- Repair/rebuilding of historical timber wall plate and tie structure with improved joinery and steel plate reinforcements.
- Concealed bolting of timber joints at strut, putin, and rafter locations, all levels.
- Reinforced concrete ring beam linked to historical timber structure as well as to new steel beams supporting the upper temple level.
- Reinforced concrete ring beam linked to historical timber structure as well as to concealed vertical rods in places where repair was necessary.
- Small wall repairs incorporate iron butterflies to increase bonding between wall layers.
- Steel bracing between inner and outer walls at floor level.
- Iron strap above timber cornice.

**Section through pagoda.** 1992-93 reinforcement of Radha Krishna Temple by KVPT included reinforced concrete ring beams at two levels and minor reinforcements of the timber structure.

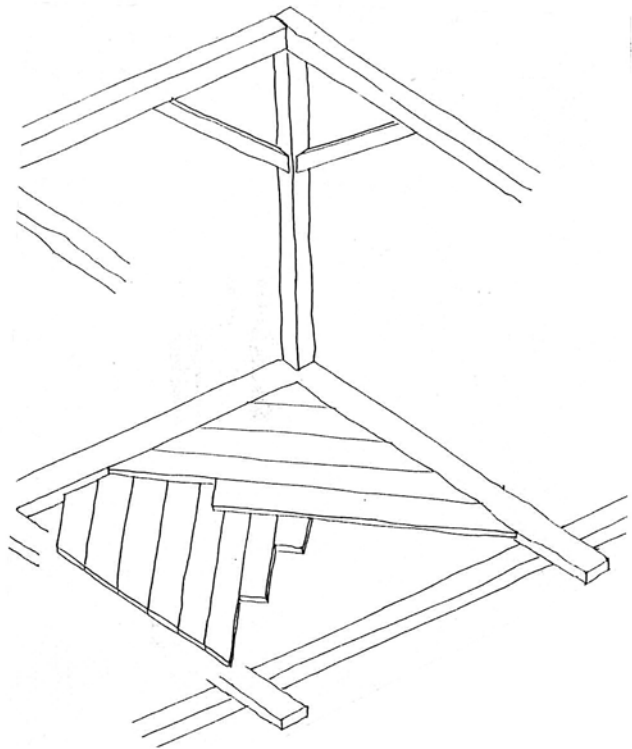
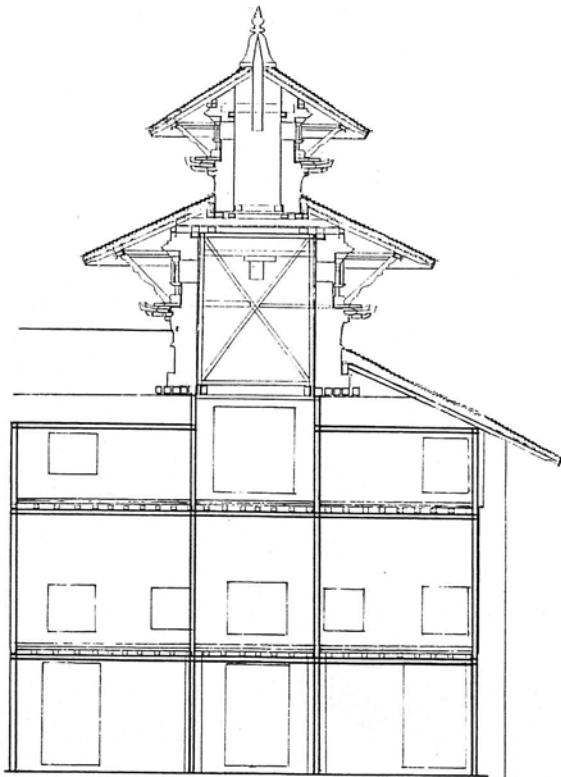

**Longitudinal section and axon detail of framework/planking.** 1994 reinforcement of the Patukva Agam include the insertion of a back-up interior timber frame which will carry loads if walls are damaged in an earthquake. Stiffening of the building is achieved by this timber back-up frame in combination with double layered angled planking floor system.

## Seismic reinforcement strategies of KVPT Projects 1992-94

Traditional double wall plate restored with inner and outer members to act as ring beam. Corner details as at Uma Maheswar Project (see previous page).

Concealed bolting of every third rafter to wall plate and purlin. Rafters notched to wall plate.

Double layer sal planking 1" thickness laid at right angles to each other and 45 degrees to building to act as rigid plate. Nailed to joists in staggered pattern.

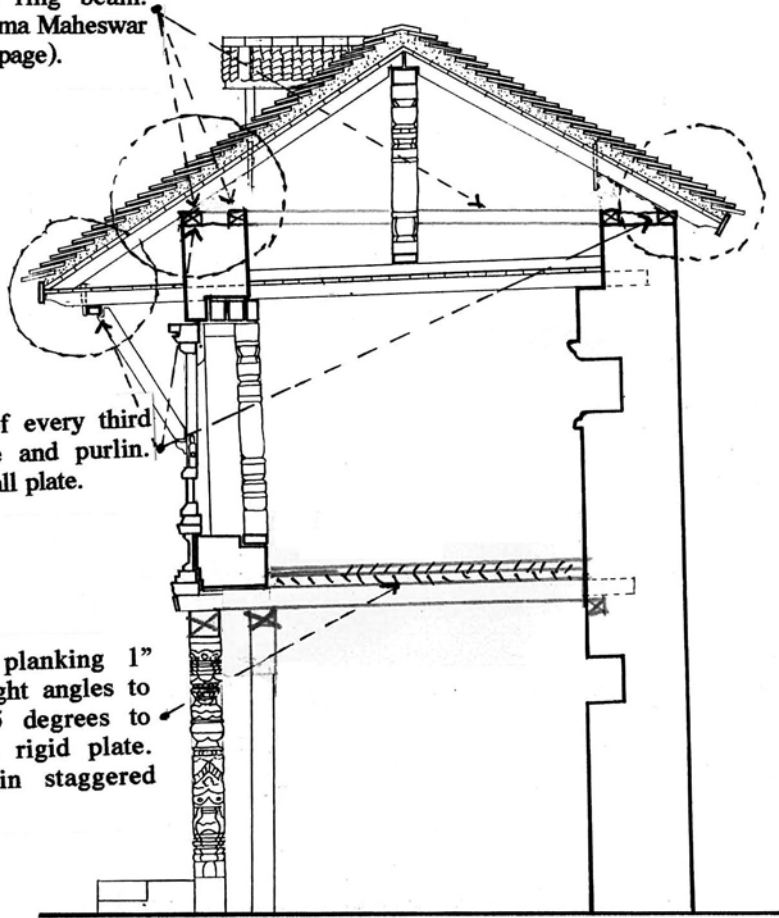

**AYAGUTHI SATTAL**  
**PROPOSED SEISMIC REINFORCEMENTS**  
 KATHMANDU VALLEY PRESERVATION TRUST  
 DRAWING BY SUSHIL RAJBHANDARI, OCTOBER 1994

applications, is necessary for dust reduction. When a tar felt membrane is proposed, the planking provides a smoother base.

In the Ayuguthi Sattal, the new planking used for first floor floor will be developed as a stiff plate through the following means. The layers of 1" thick planking can be doubled, laid at right angles to each other and 45 degrees to the building geometry. Nailing is done in a staggered pattern. Lastly, by inserting blocking between the joists at wall locations a ring beam-like effect is created, to this frame the planking and joists are attached.

## **5.02 Walls fabric: damp proof course (dpc)**

The introduction of an 24 gauge/.46 mm copper sheet damp proof course is proposed based on the following considerations:

The use of stainless steel or lead in this application is precluded by the difficulties of procuring imported materials in Nepal. Even with government support and substantial pre-planning, efforts to procure imported conservation materials (stainless steel sheets, moisture barriers) in past KVPT projects have failed. Thus, although one can only recommend such imported materials when no local satisfactory substitute is available. In this case, the use of copper will demonstrate an economical and less invasive alternative to the local norm of concrete.

Impregnating chemicals for use as a dpc have never been tested in Nepal where application would be risky given the traditional configuration of masonry walls (constructed in mud mortar and with many voids in a middle fill layer of rubble, see section 3.1). A concrete or reinforced concrete dpc is considered inadvisable given potential damage to the masonry from travelling salts.

Installation would be achieved by opening up of the masonry walls in consecutive small areas to install a continuous shield. This work is to be done after partial roof dismantlement to reduce loads on the masonry walls. Jointing of the copper sheets will be double-locked and sealed by soldering.

In general, damp-proofing is still an unsolved technical challenge here. The opportunity to test an old-fashioned (but in Nepal untested) experiment with copper will thus be useful. This installation will be accomplished in stages by opening up arched areas approximately 24" long ( 5 courses high), inserting the copper sheeting through the wall, then closing up and doing adjacent area. Several days curing time will be given between opening up of adjacent wall areas.

### **Fabric general**

As discussed above under structural issues, necessary patches of brick veneer will be made using historical bricks and mud mortar. Stranded stainless steel now in stock with the Trust will be inserted as necessary to strengthen at these patched locations.

### **Finishes**

The interior ground floor cement plaster will be removed. A test location shows that the brick is not damaged by this removal and can be left exposed. This exposed common brick would be typical of historical resthouse ground floors.

## **5.03 Wall openings and decorative elements**

### **Dalan + columns**

Although these elements are completely structurally denatured, one column will be reinstalled (with a new concealed structural core) as a memory to the historical elements, which before termite damage were superb examples of carving. At least two of the column capitals appear to be reusable. Structural consolidation of these otherwise unusable elements with an epoxy resin is under consideration. It may also be possible to join the outer carved portion of the capital onto a new inner core. Sal timber will be used in these locations.

New sal timber beams (inner and outer) matching the size of the historical members will replace the damaged lintel of this opening.

### **Doors and windows**

In general only gentle cleaning with a mild detergent of these components is necessary. As not a fragment survives of the central bay window's latticed shutters, an historically appropriate design will be developed for their replacement.

A sheet of glass will be attached to the back side of the lattice to allow modern use, with minimal visual effect.

## **5.04 Roof and floor structure**

As discussed above under general structural issues related to seismic consolidation, the timber structure of the building will be almost completely replaced due to the amount of termite and wet rot damage. This rebuilding will incorporate several changes in detail to allow the structure to act more efficiently in an earthquake. The treatment of the new timber with diffusible borate preservative will protect measure against drywood termite attack, although monitoring will be critical.



The timber floor and roof structure will be rebuilt in a mixture of pine and sal timbers, adze finished, using in the traditional rafter and joist sizes 4" x 3" on flat and spacing of rafters and joists 1' on center. These are all norms of the traditional timber structures of the Kathmandu Valley.

Sal timber has been used for joists and rafters in virtually all local and international conservation projects of the last two decades, although there is no evidence to suggest that this was an historical application of the wood. Our investigations have shown that sal was only used for beam and column locations and exterior openings, especially carved elements. All other members like rafters and joists were traditionally in pine. This combination of pine and sal is proposed for the Ayuguthi structure. The pine's advantage is a reduced weight for the roof structure; its disadvantage is that it must be well maintained to prevent water damage. This latter problem can and will be compensated for by the application of Wykamol wood preservative, a preventive measure against termites as well.

A necessary and critical improvement to the historical detailing of the timber structure is the peg detail (Nepali: *chukul*). In historical examples and especially in recent roof repairs, the extension of the timber peg into the mud bed of the tile cover has allowed water to penetrate to the heart of the rafter. The timber peg has both structural and visual purpose in the traditional construction and is therefore necessary to maintain. If the peg is cut at the planking level, i.e. below the proposed moisture membrane, the water penetration problem is simply eliminated.

#### **Control of drywood termites**

Diffusible borate preservative chemicals are proposed for the curative treatment of reused timbers and preventative treatment on new timbers. Traditional practice has employed kerosene for treatment. None of the international projects in the Kathmandu valley has addressed termite treatment. Based on the greater diffusability of the borate products, they are preferred to Wykamol, which the DoA stocks.

In reused members, damaged areas will be cut out and refitted with new timber before treatment. Given the extensive repair and replacement work virtually all timbers can be treated while temporarily removed in a soaking tank to maximize penetration. In sill and wall plate locations where removal of timbers for soaking should be seriously considered, inspection of the structure has shown that replacement is necessary in all locations due to advanced decay. Choice of replacement timbers will maximize heartwood timber which is less susceptible to

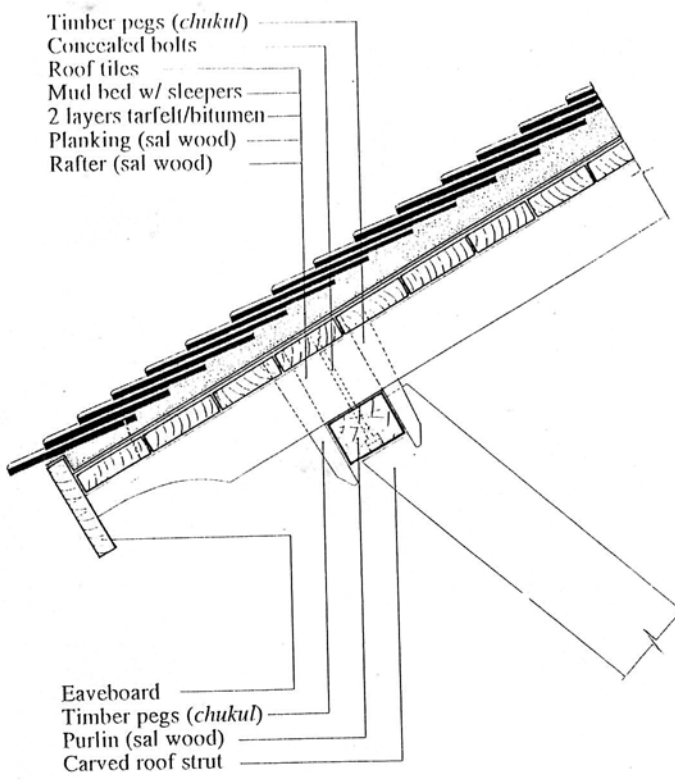
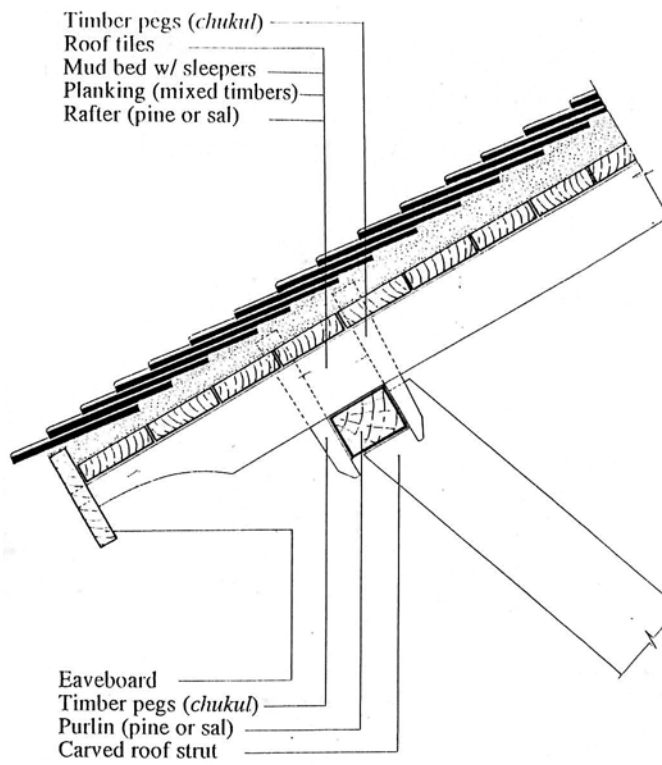

**THE "KEY" PROBLEM**

Above: Section at roof overhang: as traditionally detailed  
 Below: Section at roof overhang: Improved detailed

drywood termite attack. Ongoing monitoring of the building for future infestation is a critical component to the management/maintenance plan discussed below.

## **5.05 Roof cover**

### **Waterproof membrane**

Traditional roof construction in the Kathmandu Valley relied on the tile and mud layers for water protection. Conservation projects since twenty years have inserted waterproof membranes beneath the traditional mud bed in which the tiles rest. In recent projects we have attempted to improve on this solution through careful supervision and specifications. These include the specification of Indian standard 3 grade 1 tarfelt/bitumen (85/25 Indian standard) as moisture membrane, use of old roof tiles (which are of superior quality to the new ones), and selection of yellow mud from appropriate sites well below the ground surface.

The introduction of a concealed protective membrane against moisture beneath the mud bed of the roof tile is thus recommended as a general strategy to increase roof life. The use of high grade tar felt (Indian standard 3 grade 1) with bitumen coating (85/25 Indian standard) has been successfully used in recent conservation work in Nepal, although it is clear that its expansion and contraction caused by the changing temperatures limits its life to a maximum of 20-25 years. For this reason a more flexible material, Plasfal, is proposed. This material is produced in India with Austrian collaboration and is newly available in Nepal (see HSR appendix).

### **Lath vs. planking**

The maintenance of lath above the rafters (beneath the Plasfal and mud bed) is a traditional and historical solution not employed in government and international conservation projects in Nepal since the UNESCO Hanuman Dhoka and German Bhaktapur Development Projects in the 1970's, which substituted regular planking in this location. The use of lath has a key advantage over the planking: the smoothness of the planking necessitated the introduction of sleepers to hold the mud bed above. In local practice, the attachment of the sleepers has necessitated the counter-productive puncturing of the new membranes by nails. The irregularity of the lath surface will eliminate the need for sleepers nailed through the membrane.

### **Mud bed**

The herbicide, Karmex, will be mixed with the mud bed to prevent vegetal growth per manufacturer's specifications. A deep-dug black mud (from depths of +1 meter) will be used for this application. When properly mixed with the mud, Karmex has proven highly effective in Nepal. This imported chemical is available through the Department of Archeology.

The traditional mud bed into which the *jhingati* are laid must use the more cohesive black mud available in the valley and must be dug from depths greater than one meter to minimize organic material content. The mud will then be mixed with a herbicide per manufacturer's directions. Treatment of the mud with anti-vegetal chemicals must be carefully monitored to make sure that sufficient herbicide is mixed with the mud, a quantity which is hard to estimate in the field.

The herbicide Karmex has been used extensively in the valley over the last years with mixed results. Our discussions with project personnel at various sites suggests that the American-manufactured product performs better than an Indian product of the same name. Moreover, the care taken in the mixing of the herbicide with the mud appears to be critical. At Hanuman Dhoka, the chemical has not proven fullproof, but has certainly inhibited vegetal growth for at least 15 years according to supervising engineer Hari Ratna Ranjitkar. The American Karmex will be used for proposed work, which will be closely supervised.

### ***Jhingati***

As newly produced *jhingati* are of inferior color, strength, and porosity, the project will procure old *jhingati* for replacement tiles (approximately 40%). These older more durable tiles are not difficult to find given the present rate of destruction of historical structures in the Kathmandu Valley. The old tiles will be scrubbed with mild detergent and water.

Tiles will then be soaked in siltrate solution per manufacturer's directions to reduce their absorbency. The effectiveness of this treatment is clearly illustrated on the recently rebuilt Cyasilin Mandap in Bhaktapur, where samples of treated and untreated tiles (new tiles) have weathered very differently. In just two years, the untreated tiles have become covered with moss, while treated bricks are moss-free. The poor performance of the new untreated tiles contrasts greatly with those of ten years ago, installed by the Bhaktapur Development Project. Those tiles were also not treated, but remain moss free to date because of their more highly-fired and moisture-resistant composition.

As at Hanuman Dhoka, the bottom roof tiles (above the eavesboard) will be drilled and nailed in place as they are highly susceptible to being knocked off. They will be attached with headless nails, however, as the Hanuman Dhoka installation with regular nails necessitated removal of one square feet of adjacent tiles to replace one bottom *jhingati*. The top tiles will also be drilled and nailed into the mud bed, as this layer of tiles is vulnerable to dislocation by pigeons.

As it is difficult to find old ridge tiles (*Newari-nyakuca*) or corner aviform tile, the project will custom order necessary new tiles (75%) to match historical size and shape. The exact size of the missing upper roof aviform tiles will be extrapolated by the proportional relationships seen on many historical buildings (smaller roof-smaller corner tile). Project personnel will monitor production of these tiles to assure the best possible quality. They will be soaked in siltrate solution per manufacturer's directions.

The stacked lower ridge tiles will be held from slipping by the introduction of a steel angle (painted with anti-corrosive paint) beneath the lowest 16 tiles as introduced by the Hanuman Dhoka Project. The "L" form literally hooks the bottom-most tile and is held in place by the weight of the upper tiles. It is concealed by the tile traditional placed at the bottom tilted in the opposite direction.

### **5.05 Interior**

On the ground level the common brick walls will be left exposed. On upper and attic floors, a traditional mud plaster will be replaced. This plaster will then be white-washed with a lime mixture (Nepali: *chun*).

## Bibliography

### Nepalese architecture and art

Anderson, Mary M. The Festivals of Nepal. London: George Allen and Unwin, 1971.

Bannerjee, N. R. Nepalese Architecture. Dehli: Agam Lala Prakashan, 1980.

Gutschow, Niels. "Gorkha: the Architectural Documentation of Two Palaces from the 18th and 19th Centuries". Journal of the Nepal Research Center (vol. vii, 1985). Wiesbaden: 1985.

Gail, Adalbert. Tempel in Nepal. Graz: Akademische Druck- u. Verlagsanstalt, 1984.

Gutschow, Niels, Bernhard Koelver, and Ishwaranand Shresthacarya. Newar Towns and Buildings. Germany: VGH Wissenschaftsverlag Sankt Augustin, 1987.

Gutschow, Niels. Stadtraum und Ritual der Newarischen Staedten im Kathmandu-Tal. Stuttgart: Verlag W. Kohlhammer, 1982.

Kathmandu Valley: The Preservation of Physical Environment and Cultural Heritage, a Protective Inventory. 2 vols. Vienna: Anton Schroll.

Koelver, Bernhard. Re-Building a Stupa. Bonn: VGH Wissenschaftsverlag, 1992.

Korn, Wolfgang. Traditional Architecture of the Kathmandu Valley. Kathmandu: Ratna Pustak Bhandar, 1979.

Kramisch, Stella. The Hindu Temple. Dehli: Motila Banarsidass (rpt. of 1946 ed.), 1976.

LeBon, Gustave. Voyage au Nepal. Bangkok: White Orchid Press, 2nd reprint 1986, 1883-86 Paris edition.

Macdonald, A. W. and Anne Vergati Stahl. Newar Art. New Dehli: Vikas Publishing, 1979.

Manandhar, Inan Kaji. "Our Traditional Method of Building Construction" in Rolamba v.III no. 3, Kathmandu, 1983.

Pal, Pratapaditya. Art of Nepal. Berkeley: University of California Press, 1985.

Pal, Pratapaditya. "The Divine Couple in Himalayan Art", Arts of Asia v.22 #1, Jan-Feb 1992.

Pal, Pratapaditya. Vaisnava Iconology in Nepal: A Study in Art and Religion. Calcutta: Asiatic Society, 1970.

Pieper, Jan. "Three Cities of Nepal." in Shelter, Sign, and Symbol, edited by Paul Oliver, pp.52-69. London: Barrie and Jenkins.

Parajuli, Yogeshwar K. Bhaktapur Development Project: Experiences in Restoration and Preservation in a Medieval Town (1974-1985). Frankfurt: Deutsche Gesellschaft fuer Technisches Zuzassearbeit, 1986.

Rau, Heimo. "Workshops of Traditional Newar Woodcarving: A Stylistic Analysis". Journal of the Nepal Research Center, (vol vii. 1985) Wiesbaden: Franz Steiner Verlag, 1985.

Samsara, Sri Brahma. Nepalko Mahabhujkampa 1990 B.S. (Nepal's Great Earthquake of 1934 A.D.) Calcutta, Uttardarmasar Ratnakar Press, 2nd ed., 1935.

Slusser, Mary S. "Indresvara Mahadeva, a Thirteenth Century Nepalese Shrine". Rpt. from Artibus Asiae, vol XLI, 2/3.

Slusser, Mary Shepard. Nepal Mandala. Princeton: Princeton University Press. 1982.

Wiesner, Ulrich. Nepalese Temple Architecture. Leiden: E.J. Brill, 1978.

Wright, Daniel. History of Nepal. New Dehli: Asian Publication Services, (rpt. of 1877 ed.), 1990.

Zimmer, Heinrich. The Art of Indian Asia. Princeton: Princeton University Press, (pprbk ed.; 1946 1st ed), 1983.

## Conservation/Technical

Buildings at Risk: Seismic Design for Practicing Architects. Washington: American Institute of Architects/Association of Collegiate Schools of Architecture, 1992.

Denslagen, Wim. "Restoration Theories East and West". in Transactions: Association for Studies in the Conservation of Historic Buildings, v. 18, 1993, pp. 3-7.

Feilden, Bernard. Conservation of Historic Buildings, London: Butterworths, 1982, rpt 1989.

Fitch, James, Marston. Historic Preservation: Curatorial Management of the Built Environment. Charlottesville: University of Virginia, 1990.

"International Symposium on the Conservation and Restoration of Cultural Property: the

Conservation of Wooden Cultural Property"  
Tokyo: Organizing Committee of the International Symposium on the Conservation and Restoration of Cultural Property, November 6, 1981.

Langenbach, Randolph. "Bricks, Mortar, and Earthquakes: Historic Preservation vs. Earthquake Safety" in APT Bulletin, vol XXI, no.3/4, 1989.

Mack, Robert C. "Repointing Mortar Joints in Historic Brick Buildings", in Preservation Briefs published by the Interagency Historic Architectural Services Program, National Park Service.

Parajuli, Jogeshwar. Experiences in Preservation and Restoration in a Medieval Town (1974-1985). Kathmandu: Sahayogi Press, 1986.

Pearson, R.S. and Brown, H.P. Commercial Timbers of India, vol I. Calcutta: Government of India, 1932.

Sanday, John. Building Conservation in Nepal. Paris: UNDP-UNESCO, 1978. (UNDP/NEP/71/006-UNDP/NEP/74/003 Technical Report).

Sanday, John. "The Hanuman Dhoka Royal Palace Kathmandu—Building Conservation and Local Traditional Crafts". London: AARP (Art and Archaeology Research Papers).

Sekler, Eduard et al. Masterplan for the Conservation of the Cultural Heritage of the Kathmandu Valley. Paris: UNDP/UNESCO, 1977.

Theophile, Erich and Rohit Ranjitkar. "Timber Conservation Problems of the Nepalese Pagoda" in ICOMOS International Wood Committee 8th International Symposium, Proceedings. Tapir Publishers, 1994.





**APPENDIX 1**  
**A TRADITIONAL LEGEND/ LIST OF GUTHIARS**

## A Legendary story about the Ayuguthi Sattah

as recorded by Nutann Sharma, 1993.

Once the sister of the king of Patan, known as the Queen, came to Patan for *kija puja* (Nepali: *bhaitika*) the worship of one's brothers by female family members during the Dasain festival. Before the Queen arrived, however, her brother was taken sick and passed away. He was her only brother, and the poor queen was left with no brother to worship, so she decided to build this Ayuguthi Sattal or resthouse. She endowed the building with 10 ropanis of land to perform a ritual similar to Bhaipuja every year on Pausa Purnima (full moon in the month of Poush).

A document dated 1919 B.S. ( 1852 A.D.) describes the *puja* at Pausa Purnima: "...at the Ayuguthi there is an arrangement of 12 *yomaris* (sweet pastry). one duck, one goat, and Kagma player during the *puja*. Dhauvalal Lakhe describes the *puja*.

"A *mandala* should be drawn inside the house on the first floor, as for Bhaitika. Hot water should be given to the guthiars to wash their hands, legs, and mouth. *Tashi* fruit should be worshipped and a duck sacrificed at the nearby Bhimsen Temple.

### List of guthiars, BS 2012 (A.D. 1955) and present

A document dated 2012 B.S ( 1955 A.D.) lists as guthiars the following:

Ganesh Raj Lakhe  
Bhaktilal Joshi  
Purnaman \_\_\_\_\_ (illegible)  
Son of the brother of Chakraraj from Bakumbahal  
Laksmilal from Mangalbazar  
The two wives of Siddhilal from Daubahal  
Mijakaman from Nasacuka  
Bekhalal from Dathuche

### Additional guthiars listed in recent interviews

Nemaraj Joshi of Bakumbahal  
Khanga Bahadur Lakhe Shretha of Mangalbazaar  
Laksmilal Lakhe of Mangalbazaar  
Gajendra Srestha of Nahpasah



## Ayuguthi Sattal Restoration Project An Historic Resthouse on Patan Darbar Square

Status Report April 1, 1995

### Background

The Ayuguthi Sattal is an eighteenth century two-story resthouse defining the northern perimeter of Patan Darbar Square. Although extremely dilapidated and in danger of structural collapse, the structure retains almost all of its historical carvings and facade veneer brick. The small scale and semi-public nature of the historic building make it critical to the urbanistic definition of the Darbar Square, which centuries ago was defined by many more of such small scale resthouses. The Kathmandu Valley Preservation Trust has been active over the last four years in securing 75% of the necessary funds for its repair, shoring up the building to prevent injury to occupants and further loss of historical materials, and using the building as a publicity device to publicize the loss of historic resthouses in Kathmandu Valley, *Nepal's most endangered species*.

Project funding comes from the American Andy Warhol Foundation, GTZ/UDLE, Kathmandu Valley Preservation Trust (KVPT), and private donors including Mr. Himalaya Pandey and Mr. Watson B. Dickerman.

Based on meetings held in November 1994, the Department of Archaeology (DoA) was able to secure official project approval from the three concerned government agencies in December 1994, namely, the Finance Ministry, Ministry of Education, Social Welfare, and Culture, and the National Planning Commission.

It should be stated that the original goal was to repair the building as quickly as possible and in spite of complex ownership claims. It was felt if we waited the many years for misappropriated or contested ownership claims to be reassigned, the building would be lost. Thus, the project set out only to repair the building and not to interfere with property disputes. This move was in itself novel for preservation in Nepal.

### Recommendation for Nationalization

Given the legal complications of the project the Department of Archaeology requested the expertise of the Ministry of Law and Legal Reform before progressing with the work.

The Law Ministry in February 1995 then recommended that the building be nationalized under section 7 of the Ancient Monuments Act "in light of the owner's inability to maintain a monument of artistic and historical importance". This would be the first case for a monument in Nepal to be nationalized due to its endangered status. The Law Ministry further recommended that HMG compensate the owners under provisions of the new constitution, compensation which would not have been necessary under the provisions of the Ancient Monuments Act. Furthermore, the Law Ministry recommended that compensation be undertaken *before* repair of the building, as the value of the building will be significantly increased by the repair/reconstruction project.

### Opportunities for the future

This nationalization mechanism which exists in the current Ancient Monuments Act has to date not been exercised--it provides a critical precedent for monument protection in this country in the following ways.

When individuals control historical buildings of national or international importance, one strategy is to let them deteriorate until collapse, thus facilitating approval for a new replacement structure. This precedent would give HMG the critical mechanism to identify and save through nationalization the most important "A Class" monuments, those which are under intentional threat as above described, or as is more often the case, are endangered by unresolved property disputes. The procedures for financial compensation under the new constitution assure that the private owners would be fairly treated. Where disputes are ongoing, the compensation would be deposited on account, to be distributed upon settlement of disputes.

As the last UNESCO/ICOMOS mission has warned, privately owned monuments are clearly the most threatened historical buildings in Nepal. Nationalization of course cannot be recommended in all or even many cases, but for the most important buildings, especially in the UNESCO World Heritage Sites, it provides a necessary mechanism and precedent.

The Kathmandu Valley Preservation Trust is presently asking all supporters of historic preservation in Nepal to urge the Minister of Education, Social Welfare and Culture to accelerate this project. Given the extremely dangerous state of repair of the resthouse, if nationalization and repair does not happen as soon as possible, there may not be anything left to save.

## **Status Report: Ayuguthi Sattal**

**March 15, 1996**

The successful nationalization of the structure last month is a significant victory for the structure and preservation in general. Not only did HMG take action in this case, but also in its provision of a generous compensation (approximately \$8,000) to the occupants has demonstrated a serious commitment to saving this structure.

The Nepal Heritage Society contributed to the publicizing of this joint effort by the Department of Archaeology and the KVPT in its showcasing of the project in a television spotlight and talk program.

The KVPT is monitoring the building closely to prevent further damage while fundraising efforts are undertaken. A significant shortfall in funding will have to be met before work can be undertaken. KVPT hopes to begin the project in fall of 1996.



**APPENDIX 3**  
**TECHNICAL INFORMATION**





## MICROTECH DUAL PURPOSE AQ

### SPECIAL PROPERTIES

- Unique microemulsion technology
- Low odour (only ca. 2% solvent after dilution)
- Excellent penetration of timber; fast drying
- Non-flammable
- Highly effective against insects and fungi
- Rapid re-occupation of treated areas

### DESCRIPTION

Microtech Dual Purpose AQ is a microemulsion concentrate wood preservative based on cypermethrin (insecticide) and Polyphase (fungicide), for the eradication of common furniture beetle (*Anobium punctatum*) and other wood boring beetles in building timbers and to give protection from fungal decay during the drying period after eliminating sources of dampness.

Microtech Dual Purpose AQ is approved under the Control of Pesticides Regulations 1986 for use as directed (HSE No 5453).

FOR USE ONLY AS A WOOD PRESERVATIVE

FOR USE ONLY BY PROFESSIONAL OPERATORS

This product is manufactured under a quality system complying with BS 5750 Part 1, ISO 9001-1987, EN 29001-1987.

### SITE WORK

#### Preparation

All bats are protected under the Wildlife and Countryside Act 1981. Before treating any structure used by bats, consult English Nature, Scottish Natural Heritage, The Countryside Council for Wales, or the Department of Environment for Northern Ireland.

- a) Beetle infestations (see also Microtech Woodworm Killer AQ)

Ensure that all timbers to be treated are adequately exposed and cleaned (vacuum cleaning preferred). Any paint or varnish finishes or any severely damaged sapwood edges of timbers ("frass") should be removed prior to treatment where possible.

Remove thermal insulation in roof spaces (or roll up and completely cover) and do not reinstate until the timbers are dry. Cover fitted insulation (lagging on pipes) with polythene and cover water storage tanks with heavy grade polythene to be left in-situ after treatment. Isolate electrical circuits in the treatment area during and for 8 hours after treatment and ensure that junction boxes etc. are adequately protected against the ingress of the fluid. Remove or cover all foodstuffs before application as well as fish tanks/bowls. Do not use on beehives or beekeeping equipment or apply to surfaces on which food is prepared.

Where applicable, notify occupants of adjoining properties before treatments commence.

Display Safety Notices conspicuously during treatment and leave on site after treatment for at least 8 hours. Use only flameproof portable lighting equipment and ensure that this and any other electrical equipment is in good order.

- b) Fungal Decay - Wet Rots

As (a) above plus - locate and rectify the source of dampness. Cut out all structurally unsound timbers and make repairs isolating timbers where possible from damp masonry etc.

- c) Fungal Decay - Dry Rot

As (a) and (b) above plus - the ability of Dry Rot (*Serpula lacrymans*) to spread through masonry/concrete structures may necessitate the treatment of infected walls/floors. Overall details are given in the Green Range Murosol 20 data sheet.

Biodeterioration Section

TEST REPORT

TEST: DETERMINATION OF PREVENTIVE ACTION AGAINST *Reticulitermes santonensis*

---

EUROPEAN STANDARD: EN 118 BRITISH STANDARD: BS 6240:1982

MATERIAL TESTED: Cypermethrin microemulsion NCEF 8 (2)  
(sample NCEF 8 (2) MW 11.4.90) BRE CODE: B40

DESCRIPTION: Clear fluid, supplied by Client as ready-to-use

SUPPLIER: NCH Europe CONTACT: Mr H B Dawson

DILUENT: None

WOOD SPECIES: Scots pine sapwood

CONCENTRATIONS TESTED: Information as supplied by Client:-  
0.1 % cypermethrin (3 rates of application used)

DATE OF TREATMENT: 3 May 1990

METHOD AND RATE OF APPLICATION: A single pipette application at 100, 200  
and 300 ml/m<sup>2</sup>

METHOD & DURATION OF DRYING: Air drying for 4 weeks

AGEING PROCEDURE: Aged to EN 73: 12 weeks at 40° C and 1 m/s

NUMBER OF INSECTS PER COLONY: 250 worker termites, 3 nymphs, 1 soldier.

DATE OF EXPOSURE TO TERMITES: 19 December 1990

DATE OF EXAMINATION: 12 February 1991

PRINCIPLE OF THE TEST

Surface treatment of blocks of a susceptible wood species with the preservative, followed by division of the blocks into two test specimens.

Challenge of the test specimens by specified colonies of *Reticulitermes santonensis* and assessment of the attack suffered after exposure in specified conditions for eight weeks. Comparison of these results with those obtained from untreated control specimens.

Table 1 RESULTS OF EN 118 TEST WITH CYPERMETHRIN MICROEMULSION NCEF 3 (2)

Test specimen	Application rate	Number of live termites	Percentage mortality	Presence of soldiers (S) or nymphs (N)		Grade of attack on specimen*
A	untreated	183	27.9	4 S	-	4
B	control	181	29.7	1 S	1 N	4
C		159	37.4	1 S	-	4
D		161	36.6	1 S	-	4
E		136	46.4	1 S	-	4
F		163	35.8	1 S	1 N	4
Mean		164	35.5			
1	100 mls/m <sup>2</sup>	0	100.0	-	-	1
2		0	100.0	-	-	1
3		0	100.0	-	-	1
4		0	100.0	-	-	1
5		0	100.0	-	-	1
6		0	100.0	-	-	0
Mean		0	100.0			
7	200 mls/m <sup>2</sup>	0	99.6	-	1 N	0
8		0	100.0	-	-	0
9		0	99.6	-	1 N	0
10		0	100.0	-	-	0
11		0	99.6	-	1 N	0
12		0	100.0	-	-	0
Mean		0	99.8			
13	300 mls/m <sup>2</sup>	0	99.6	-	1 N	0
14		0	100.0	-	-	0
15		0	100.0	-	-	0
16		0	99.6	-	1 N	0
17		0	100.0	-	-	0
18		0	99.2	-	2 N	0
Mean		0	99.7			

\* see Appendix for definition of grades of attack.

## SCOPE OF THE METHOD

This report is concerned only with the toxicity of the preservative under test to the insects as specified in the Standard. The effectiveness of this material as a preservative depends not only on its toxicity but also on certain other factors such as the method of application and the relative penetrability of different species of wood.

These additional considerations are not within the scope of the Standard, and the result of this test cannot, therefore, be taken to mean that the material under test has been fully evaluated as a preservative.

## INTERPRETATION

The interpretation and practical conclusions that can be drawn from a test report demand a specialised knowledge of the subject of wood preservation and for this reason, this report cannot itself constitute an approval certificate.

## RESULTS

Detailed results for each application rate and for untreated control specimens are shown in Table 1.

An application rate of 100 mls/m<sup>2</sup> permitted slight damage (grade 1 - see Appendix) to the surface of five of the six test specimens.

The 200 and 300 mls/m<sup>2</sup> application rate provided complete protection against attack by *Reticulitermes santonensis*.

All untreated controls showed the maximum damage rate (grade 4), indicating a valid test. Mortality of termites in the control specimens ranged between 27.9 and 46.4 %.

## CONCLUSIONS

When tested according to EN 118, at a loading of 100 mls/m<sup>2</sup>, and after ageing to EN 73, Cypermethrin microemulsion NCEF permitted slight damage by *Reticulitermes santonensis*.

When tested according to EN 118, at a loading of 200 and 300 mls/m<sup>2</sup>, and after ageing to EN 73, Cypermethrin microemulsion NCEF provided complete protection against attack by *Reticulitermes santonensis*.

TEST CONDUCTED BY *L. Sping*.....L D Sping

TEST SUPERVISED BY *Susan J Read*.....S J Read

REPORT APPROVED BY *R W Berry*.....R W Berry

18 February 1991

- 0 No attack.
- 1 Attempted attack: - superficial gnawing or nibbling of insufficient depth to be measured.
- 2 Slight attack: - surface attack (<1 mm) limited in extent to a maximum of a quarter of the exposed surface,  
- or a single tunnelling to depth of less than 3 mm with no other sign of attack.
- 3 Average attack - surface attack (<1 mm) extending over more than a quarter of the exposed surface,  
- or erosion (1-3 mm) on an area equal to, or less than, a quarter of the exposed surface,  
- or tunnelling, at points greater than 3 mm, but not leading to cavities, and not transversing the test specimen.
- 4 Strong attack - erosion on more than a quarter of the exposed surface  
- or attack penetrating greater than 3 mm leading to cavities in the main body of the test specimen, or not leading to cavities but transversing the specimen.

*First International Conference on*  
**Wood Protection with  
Diffusible Preservatives**

Proceedings 47355

**Margaret Hamel**  
Proceedings Editor

**Doris Robertson**  
Program Coordinator

Papers for this proceedings were presented at a conference sponsored by the USDA Forest Service in cooperation with the Mississippi Forest Products Laboratory, Mississippi State University; the Forest Research Laboratory, Oregon State University and the Forest Products Research Society. The conference, titled "Wood Protection with Diffusible Preservatives," was held in Nashville, Tennessee, November 28-30, 1990. Typeset directly from author-prepared copy, these papers are without technical review. Individual authors assume responsibility for views expressed.

## Abstract

Common fungi and insects that damage unseasoned lumber, seasoned lumber, and final wood products are discussed. A review is given of the extensive use of borates and fluorides (diffusible preservatives) for protection of wood products manufactured from a wide variety of tropical hardwood species. This protection provides long-lasting housing and wood-based products in local economies of some African and Asian tropical regions. Diffusion treatments aid in attaining three tropical forestry management objectives: 1) greater use of non-durable wood; 2) less reliance on declining volumes of durable species; and 3) increased within-country processing. There has been limited use of diffusion treatments with borates or fluorides for protection of North American and Latin American hardwoods. Results of recent experiments on dip, pressure, or thermal treatments of a tropical hardwood, banak (*Virola* spp.), and dip-diffusion treatment of several domestic hardwoods with disodium octaborate tetrahydrate (Tim-Bor®) and ammonium pentaborate/sodium sulfate (Am-Bor-S®) are discussed.

## Common fungal and insect problems

During air-drying, lumber may be discolored by fungi (mold, mildew, sapstain) and attacked by various beetles, including ambrosia beetles (families Platypodidae and Scolytidae), false powderpost beetles (family Bostrichidae), and true powderpost beetles (family Lyctidae). In North America, fungal discoloration and ambrosia beetles are the most common problems. Infestations of ambrosia and other beetles sometimes are introduced into structures when products are made from air-dried lumber.

Untreated, seasoned wood lacking a finish may be attacked by various insects, most commonly true powderpost (lyctid) beetles and drywood termites (family Kalotermitidae). Powderpost beetles and drywood termites obtain their food and moisture needs from wood they attack. Drywood termite protection is especially important in tropical countries, the southern coastal perimeter of the United States, and Hawaii. Lyctid beetles commonly attack wood during processing, distribution, or storage before final use; the termites most commonly attack wood after it is in final use. Undetected beetle infestations in wood products often are distributed into business premises or structures. This damage causes product complaints, damage claims, and lawsuits that harm business relationships (2,23,34,35). The likelihood of beetle problems is greatest for low density tropical woods and in tropical or warm, humid southern regions of temperate climates. Adult insects are present only in warm weather in the United States, but are always present in the tropics. Also, only sapwood portions of some domestic hardwood species are very susceptible to beetle attack,

whereas all portions of less durable tropical hardwoods are susceptible. Therefore, treatments that thoroughly penetrate wood to prevent attacks are preferred in tropical countries. Remedial control of beetles by fumigation, insecticidal sprays, or replacement of infested wood are established practices in the United States. Drywood termite infestations are often controlled by expensive tent fumigations.

## Treatment limitations

Current measures used in the United States are designed to protect wood from fungi and/or insects until the wood is kiln-dried. These measures include: rapid turnover of log and lumber inventories, log storage under continuous water sprays, and momentary dipping of lumber into an unheated fungicidal solution during warm weather months (36). To prevent ambrosia beetle attacks, an insecticide is commonly used in combination with the fungicide. This chemical treatment gives shallow penetration in unseasoned wood and provides temporary protection.

Diffusion treatments with borates at the sawmill combine the treatment for temporary protection and the final treatment needed when wood is in its final use. This has the advantage of reduced costs (16).

Borates require use of other biocides with them to prevent discoloration by mold, mildew, and staining fungi or enzymatic stain (1). Although borates do not prevent tunneling by ambrosia or false powderpost beetle adults, they do prevent survival of their offspring.

## Tropical hardwoods

### Worldwide review

Protection needs differ depending on whether the tropical hardwood, and domestic lumber as well, is treated for use in local economies or for export. When using borates, these differences influence the required treating equipment, the effectiveness, the acceptable labor-intensiveness of treatment processes, and the variety of wood species to be treated. For example, a wide variety of less known, less durable species are treated to provide products such as longer lasting housing for use in local economies where the hazards from decay fungi and insects are great. These treatments contribute to attaining at least three tropical forestry management objectives: greater use of nondurable wood, less reliance on diminishing stocks of durable wood, and more processing of wood within the country of origin. This creates more jobs.

When tropical hardwood products are treated for export, usually only a few commercially important species are being treated to protect them during transit to developed countries where hazards from decay fungi and insects are less severe. These products are either produced by subsidiaries of companies from developed countries or are prepared to their specifications.

# Diffusion treatment of domestic and tropical hardwood lumber for long-term protection from decay fungi and insects

Lonnie H. Williams

The author is Principal Entomologist, USDA Forest Serv., Southern Forest Expt. Sta., Gulfport, Miss.

The use of trade, firm, or corporation names in this article is for the information and convenience of the reader. Such use does not constitute an official endorsement or approval by the USDA Forest Serv. of any product or service to the exclusion of others that may be suitable. Thanks are given to those whose cooperation made the experiment with domestic hardwoods possible: Sawmills — Forest Products, Inc.; Georgia Pacific Corp.; Haywood Technical Inst. (lumber supplied by Gilkey Lumber Co.); Linden Lumber Co.; Mead Hardwoods; Memphis Hardwood Flooring Co.; Sondheimer Lumber Co.; Chemical suppliers — Angus Chemical Co.; AZ-Bor Corp.; Buckman Laboratories; U.S. Borax and Chemical Corp.; and Sample collection — Forest Serv. Region 8, Forest Pest Management; and Mississippi Forest Prod. Lab., Mississippi State Univ.

Preservation manuals (13,14,29) are available that provide: 1) excellent examples of simple, low-cost treating equipment; 2) detailed diffusion treating procedures; 3) guidelines for treatment requirements and quality control; and 4) excellent discussions of the importance of wood preservation to local economies. Other references also give excellent discussions (7, 18,22,24,26).

The borax/boric acid + sodium fluoride + sodium dichromate + arsenic pentoxide (BFCA) salt mixture developed in Australia (patent) No. 246,298 of 1960-63) (25) has been widely used for several reasons. It permitted a 31 percent boric acid equivalent (BAE) concentration of borates to be used as a cold solution (25). The arsenic and fluoride gave additional protection against termites, comparable to chromated copper arsenate (CCA), making the BFCA mixture from 3 to 10 times more effective than a borax/boric acid mixture (33). However, field evaluations of BFCA-treated wood in Papua New Guinea indicated that insufficient arsenic, chromium, or fluoride may remain after planing to give any added protection over that provided by boron alone (25). Levy (25) firmly believed in the deterrent effect of boron on termites, provided alternative untreated wood was available, since termites sometimes eat treated wood if nothing else is available. Francis (18) and McQuire (26) recommended field service tests of boron only or unheated boron/fluoride treatments.

Various borax/boric acid and boric acid/sodium fluoride formulations have been evaluated for treatment of a number of tropical African woods (11,15,17). Fougerousse (15) provides treatment recommendations using borax/boric acid for obeche (*Triplochiton scleroxylon* K.

Schum), a wood from the Ivory Coast. This wood is frequently used to make expensive picture framing in Europe; however, frames imported into the United States from Europe are frequently found to be infested with powderpost beetles. Treating wood before shipment from Africa to Europe should be of significant economic benefit for everyone.

Diffusion-treated wood has been widely used for low-cost housing and other products in many parts of Africa, Asia, and the South Pacific (7,9,20,21,31,32).

### Latin America

Few published reports exist about tests with borates in Latin America (5,8,10). Of those available (12,19,27,30), none include treatment of local hardwoods. Nevertheless, the advantages of diffusion treatment of sawn timber for tropical countries have been extolled by many knowledgeable researchers, including Fougerousse (16) and Levy (24).

The most important reason for the limited attention to borates in Central or South America is the low regard given to wood-frame

housing. Masonry housing, with interior woodwork of naturally durable woods, is preferred because it is considered more resistant to insect and decay damage. For this reason, there is not a strong incentive to treat less durable woods for use in local economies found in other tropical regions. Instead, priority has been given to pressure treatment of wood with fixed preservatives, primarily to supplement demands on durable species for products in exterior exposure or ground contact.

Use of borates in Latin America by representatives of commercial firms from developed countries apparently has been limited to the protection of banak (*Virola* spp.) wood imported into the United States by a producer of pattern moldings. Because laboratory test results indicated that borate dip-diffusion treatment provided excellent protection against lyctid powderpost beetles, recommendations were made for commercial application (37). Laboratory tests with treated lumber and moldings made from treated lumber demonstrated that the borate-treated banak wood was effectively protected from lyctid beetles, subterranean termites, and decay fungi, but not from mold and mildew fungi (39).

Commercial treatments, implemented in 1982, consist of a 1-minute dip treatment of unseasoned lumber in a 25 percent BAE solution, followed by 1 week of diffusion storage in a shed. Barnes and Williams (3) found that air-dried banak lumber could be pressure treated effectively using a Lowry empty-cell process and a 2.0 percent disodium octaborate tetrahydrate solution. This process gave the best retention and penetration of preservative in the shortest possible time. A simpler double vacuum cycle was recommended if less complex equipment is desired.

Protection against lyctid beetles, assuming a required 0.2 percent BAE core retention, can

TABLE 1. — Experimental design.

Estimated total board foot volume (m <sup>3</sup> ) of lumber that was treated (half with Am-Bor-S, half with Tim-Bor)	56,252 (133 m <sup>3</sup> )
Percentage of treated volume by month:	
February	36.9
June	31.7
October	31.4
Percentage of the treated volume by dimension:	
8/4 (50 mm)	58.1
6/4 (38 mm)	1.5
5/4 (31 mm)	26.6
4/4 (25 mm)	13.8
Percentage of the treated volume by species:	
ash ( <i>Fraxinus</i> spp.)	20.9
red oak ( <i>Quercus</i> spp.)	31.7
white oak ( <i>Quercus</i> spp.)	7.4
yellow-poplar ( <i>Liriodendron tulipifera</i> L.)	22.0
white pine ( <i>Pinus strobus</i> L.)	6.6
species treated only 1 month at 1 mill:	11.4
beech ( <i>Fagus</i> spp.)	
cypress ( <i>Taxodium distichum</i> (L.) Rich.)	
hackberry ( <i>Celtis</i> spp.)	
hickory ( <i>Carya</i> spp.)	
maple ( <i>Acer</i> spp.)	
sweetgum ( <i>Liquidambar styraciflua</i> L.)	

All species dip-treated for 1 minute followed by 8 weeks of diffusion while stacked on stickers (dead-packed one mill) with the top of the stack covered by scrap boards (February and June) or 4 weeks of diffusion on stickers (deadpacked one mill) with stack enclosed by tarpaulin (October).

Six randomly chosen boards for each treatment/species combination were repeatedly sampled at 4, 6, and 8 weeks after treatment for analyses of borate penetration and content, except for October when sampling was only done at 4 weeks.

Experimental inconsistencies include: 1) treatments not done at same mills each of the 3 months; 2) red oak treated at each mill, but dimensions varied; 3) lumber was treated and diffusion stored while deadpacked at one mill but stickered at other mills; and 4) sampling after treatment was done only at 4 weeks in October.



\* = Sawmill Location

Figure 1. — Approximate locations of sawmills where borate lumber treatments were done; no treatment was done at the Louisiana mill in June and October or at the West Virginia mill in February.

TABLE 2. — Treating solutions for months of February, June, and October, 1986.

Solution by month	
February	30% BAE (boric acid equivalent) Am-Bor-S <sup>a</sup> + 1% Busan 30L <sup>b</sup> 32% BAE Tim-Bor <sup>c</sup> + 1% Busan 30L 1% Busan 30L used alone
June	30% BAE Am-Bor-S + 1% BL1067 <sup>d</sup> 32% BAE Tim-Bor + 1% BL1067 1% BL1067 used alone
October	30% BAE Am-Bor-S + 1% Amical Flowable <sup>e</sup> 32% Tim-Bor + 1% BL1067 1% BL1067 used alone 1% Amical Flowable used alone

<sup>a</sup> Am-Bor-S = ammonium pentaborate plus sodium sulphate.

<sup>b</sup> 30% a.i. 2-(thiocyanomethylthio) benzothiazole.

<sup>c</sup> Tim-Bor = disodium octaborate tetrahydrate.

<sup>d</sup> Special formulation of Busan 1009<sup>®</sup>; 10% a.i. methylene bis(thiocyanate) and 10% a.i. (thiocyanomethylthio) benzothiazole.

<sup>e</sup> 40% a.i. diiodomethyl-p-toly sulfone.



be achieved with alternate dips in hot (180°F; 82°C) and cold (ambient temperature) 2 percent BAE solutions. The combined immersion times of both dips should total about 10 minutes (4). A period of diffusion storage (24 to 48 hr.) would be needed to provide sufficient retention of chemical to prevent decay fungi.

Clearly, borate treatment of other Latin American hardwood species needs testing because many variables influence diffusion, pressure, and thermal treatment processes in commercial practice. Procedures suitable for treatment of one low-density wood species offer guidelines for treatment of another, but the most efficient, economical procedures must be developed for each commercial operation and possibly for different wood species. In this regard, commercial representatives from developed countries may find that their assistance in developing borate technology within each individual Latin American country will lead to better utilization of wood in local economies. This assistance might make borates and other biocides more readily available in many Latin American countries.

Importing preservatives into these countries often is viewed as competition to local concerns. Because beetle infestations have harmed the acceptance of some Latin American export products in the United States, use of treatments that would protect export product value, while also possibly conserving forest resources, should be regarded favorably by both exporters and importers. Furthermore, borate treatment of little known, moderately durable tropical hardwoods would seem to deserve high priority by influential programs such as the Caribbean Initiative or the Tropical Forestry Action Plan. Increased utilization of moderately durable wood in local economies has an important bearing on sustainable forestry management and the success of other tropical forestry management objectives.

### Domestic hardwoods

Presently, there are insufficient markets for use of treated wood in buildings or for construction timbers. Domestic hardwood lumber producers question the benefits of using borate diffusion treatments, particularly after learning the requirements for adequate treatment. Current available technology to provide treated end use products requires use of additional fungicides in heated borate solutions, treatment of lumber with high wood moisture content (MC), a period of diffusion storage, and treating throughout the year. Such a treatment regime is much more extensive than current procedures. Therefore, knowledge about treatment performance and costs for domestic wood species must be developed and many practical questions must be answered. For example, much of the freshly sawn lumber at sawmills in the United States may be too dry for diffusion treatments because logs are sometimes transported great distances and stored for long periods before sawing. Research on

borate diffusion treatments of domestic hardwoods, started in 1985, currently is limited to the unpublished results of several experiments by Terry L. Amburgey, Mississippi State University, and the author.

There was a need to investigate whether or not current lumber-handling procedures needed to be altered if borates were to be used for treatments to wood. To address this need, the effects of two different post-treatment storage procedures were investigated. These methods were: (1) using diffusion storage procedures that simulate current practices used at sawmills for air-drying hardwood lumber before kiln-drying, and (2) using tarpaulin covers to first restrict drying for a 4-week period.

### Materials and methods

#### Treatment procedures

Treatments were applied at six sawmills located throughout the southeastern states dur-

ing the months of February, June, and October, 1986 (Fig. 1, Tables 1 and 2). Using mobile treating equipment described elsewhere (38), the borate solutions were transported from sawmill to sawmill, heated overnight to above 130°F (54°C), and agitated before use. Before treatment, the MC of each wood species was determined from six randomly chosen samples by standard oven-dry techniques. Three species most commonly produced at each mill were treated by applying a 1-minute dip treatment to each of three packets per species; each packet contained 25 to 40 boards. The one exception was that only red oak sapwood lumber was treated at one mill in October.

#### Solution monitoring

Solution temperatures were recorded before and after treatment at each mill, but only means ( $\pm$ SD) across all mills are reported in this pa-

TABLE 3. — Mean ( $\pm$ S.D.) solution temperatures by borate and month of treatment.<sup>a</sup>

Borate	Mean ( $\pm$ S.D.) solution temperatures					
	February		June		October	
	°F	°C	°F	°C	°F	°C
Am-Bor-S	127 ( $\pm$ 3.9)	53 ( $\pm$ 1.6)	130 ( $\pm$ 3.3)	54 ( $\pm$ 1.4)	133 ( $\pm$ 3.1)	56 ( $\pm$ 1.3)
Tim-Bor	125 ( $\pm$ 4.0)	52 ( $\pm$ 1.7)	130 ( $\pm$ 3.2)	54 ( $\pm$ 1.3)	131 ( $\pm$ 4.4)	55 ( $\pm$ 1.8)

<sup>a</sup> For each borate and month, the means represent temperature readings taken before and after treatment at each of six mills, N = 12.

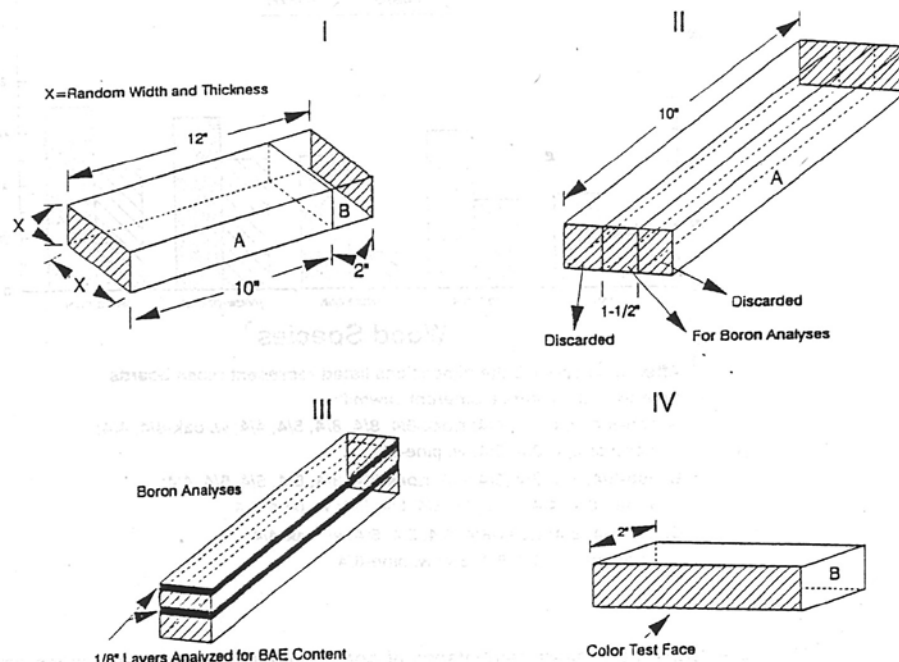
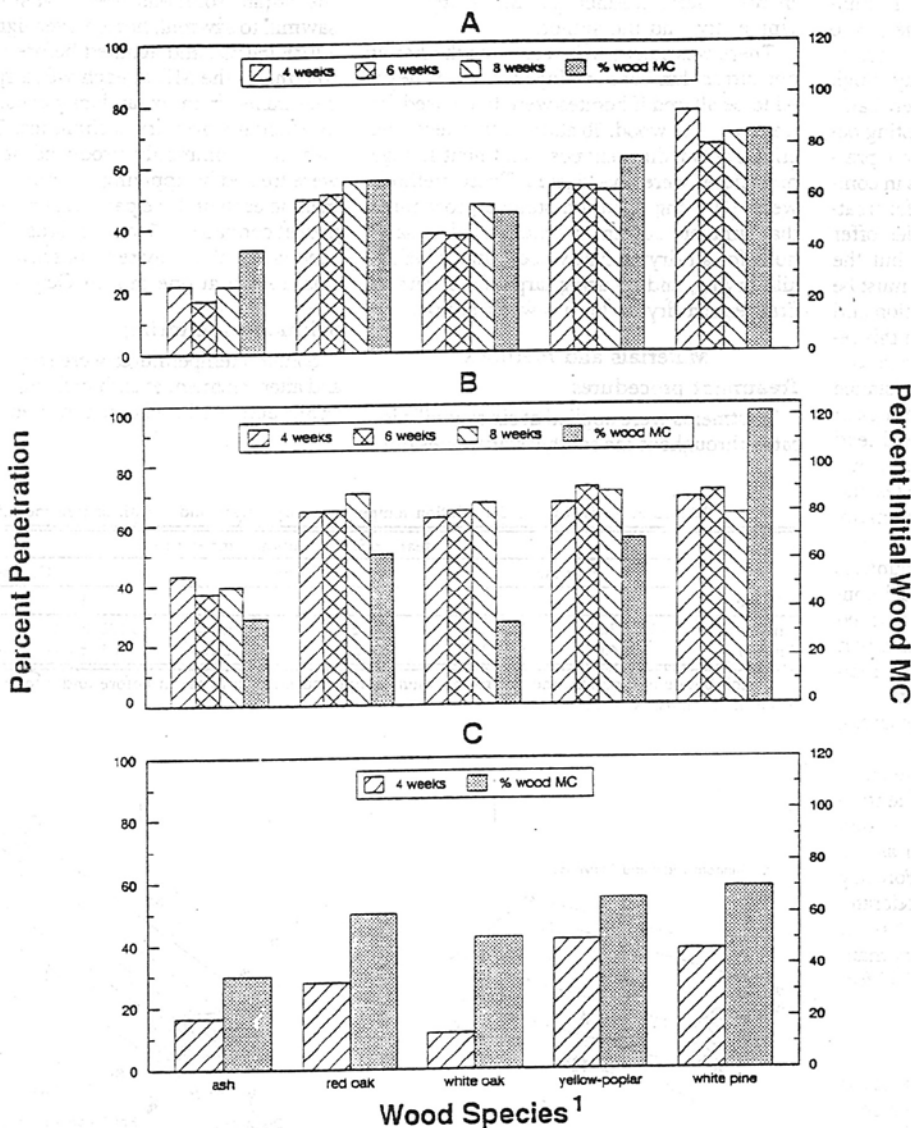

Figure 2. — A 1-foot-long (305 mm) piece (I) sawn from each sample board at 4, 6, and 8 weeks after treatment (after 4 weeks only in October) was sawn into 2-inch-long (50-mm) cross-sectional samples for color-testing (IV). A 1 1/2-wide by 10-inch-long (38- by 254-mm) strip was sawn from the center of the remaining piece, discarding the two outer pieces (II). Samples for chemical analyses of (BAE) were obtained by reducing 1/8-inch (3.2-mm) layers (III) to shavings that were further reduced to powder in a Wiley® mill with a 20-mesh screen.



<sup>1</sup> After each species the dimensions listed represent those boards treated and indicate a different sawmill:  
 A. ash-8/4, 8/4, 5/4, 4/4; r.oak-8/4, 8/4, 8/4, 5/4, 4/4; w. oak-8/4, 4/4; y.poplar-8/4, 8/4, 5/4; w. pine-8/4  
 B. ash-8/4, 8/4, 8/4, 5/4, 4/4; r.oak-8/4, 8/4, 6/4, 5/4, 5/4, 4/4; w. oak-8/4, 4/4; y.poplar-8/4, 8/4, 5/4; w. pine-8/4  
 C. ash-8/4, 8/4; r.oak-8/4, 8/4, 5/4, 5/4; w. oak-4/4; y.poplar-8/4, 8/4, 8/4, 5/4; w. pine-8/4

Figure 3. — Combined mean percentages of boron penetration into board cross sections at 4, 6, and 8 weeks after dip-diffusion treatment with Am-Bor-S during February (A), June (B), and October (C). Penetration based on color tests of board cross sections with a boron indicator. Boards were sampled from a varied number of sawmills and board thicknesses. Means represent for each month/species six board samples times the number of board dimensions listed in the footnote. Mean percent wood MC before treatment is also given.

per. Borate solution samples were taken before and after treatment at each mill and were analyzed for BAE content by Inductively Coupled Plasma-ion (ICP) spectrograph analyses. Again, means ( $\pm$ SD) across all mills are reported.

### Borate penetration

Sampling of all borate-treated lumber was done 4 weeks after treatment during all 3 months. In February and June, sampling of the same boards was repeated 6 and 8 weeks after treatment. The 1-foot-long (305-mm) samples that were used to determine borate penetration were obtained in the following manner. A 1-foot-long (305-mm) piece was discarded from one end of each of the six randomly chosen sample boards per treatment/species combination. The next 1-foot-long (305-mm) sample from each board was processed into a 2-inch-long (50-mm) cross-sectional sample for color testing (Fig. 2). The cross-sectional sample was oven-dried at 110°F (43°C) for 24 hours before color tests were done with turmeric/salicylic acid reagents. These indicate bright red when boron is present at 0.30 or more percent BAE (6). The color test results were converted to data for analysis, using a video-image analysis system (28).

Borate treatment results are reported in Figures 3 and 4 only for species that were treated in more than 1 month and at more than one mill (Table 1). However, white oak was treated only at one mill in October. White pine was treated only at one mill each month, but results with this more easily treated softwood are included for comparison.

The remainder of the sample was processed to provide samples for BAE analyses by ICP (Fig. 2). Only the mean BAE contents in 1/8-inch (3.2-mm) layers at the mid-depths (centers) of boards representing each borate/species/time combination are reported in Figures 5 and 6 for the same species as given earlier for the borate penetration results.

### Estimating solution consumption

To make estimates of solution consumption, the total board foot (BF) volume of borate-treated lumber of each species was calculated by assuming all boards were 6 inches (152 mm) wide by 10 feet (3,048 mm) long by the thickness, either 4/4, 5/4, or 8/4 (25, 32, or 50 mm). Typical of hardwood lumber, however, the boards were random widths, but lengths usually were 8 to 10 feet (2,438 to 3,048 mm). Treating solution depths were measured to the nearest 1/4 inch (6.4 mm) before and after treatment at each mill and were used to estimate solution consumption per 1,000 BF (2.4 m<sup>3</sup>).

### Data analyses

No statistical comparisons between mills, species, or month in the year were possible under the experimental design. Boards were considered to be sufficiently treated when the mean BAE content at mid-depth was greater than 0.2 percent BAE (39).

## Results and discussion

### Solution monitoring

Results of monitoring treating solutions indicated that mean temperatures were in a reasonably close range from month to month and between borates by month (Table 3). Mean solution concentrations were within a 5 percent BAE range from month to month, and the concentrations of the two borates were essentially the same each month (Table 4).

### Borate penetration

The mean percentages of board cross sections containing 0.30 or more percent BAE are shown for four hardwood and one softwood species at 4, 6, and 8 weeks after each month's treatment with ammonium pentaborate/sodium sulfate as Am-Bor-S (Fig. 3) or disodium octaborate tetrahydrate as Tim-Bor (Fig. 4). The mean initial MCs of each species are shown in each figure as well.

Some of the inconsistencies mentioned in Table 1 are apparent from the footnotes to each bar chart. In each figure the dimensions treated for each species and the number of sawmills where treating was done are given (Figs. 3 and 4). White pine was treated at only 8/4 (50 mm) thickness and at one mill. All other species (except white oak in October) were treated at two to six mills and were mixed dimensions, but predominately 8/4 (50 mm). Treated boards of all species contained undetermined proportions of sapwood and heartwood.

In general, the February and June data (Figs. 3 and 4) suggest that about 50 to 65 percent of red oak and yellow-poplar board cross sections were penetrated with 0.30 or more percent BAE within 4 weeks. The more easily treated white pine showed 69 to 78 percent penetration within 4 weeks. The failure to increase the percentage of penetration with additional time possibly suggests that the borate was becoming diluted within the wood and was less readily detected. A more likely cause is that the lumber was losing moisture in stickered storage causing diffusion to either cease or to proceed slowly. However, color test results suggest that storage under tarpaulins (Figs. 3,4) did not improve penetration for any species. This may have been because the initial MCs of lumber covered with tarpaulins were lower than that of the lumber treated in February and June and not covered.

The mean MCs for lumber of each species were usually highest in February, lower in June, and lowest in October. This trend was surprising; lumber sawn from logs in February was expected to be the driest because the logs had been stored through the winter. Higher MCs were expected from fresh logs being cut in June and October. Also, most mills stored their logs under sprinkler systems only in the warm weather months. However, a very hot, dry summer and fall occurred during 1986, the year of treatment. The lumber may have dried considerably before sampling, though

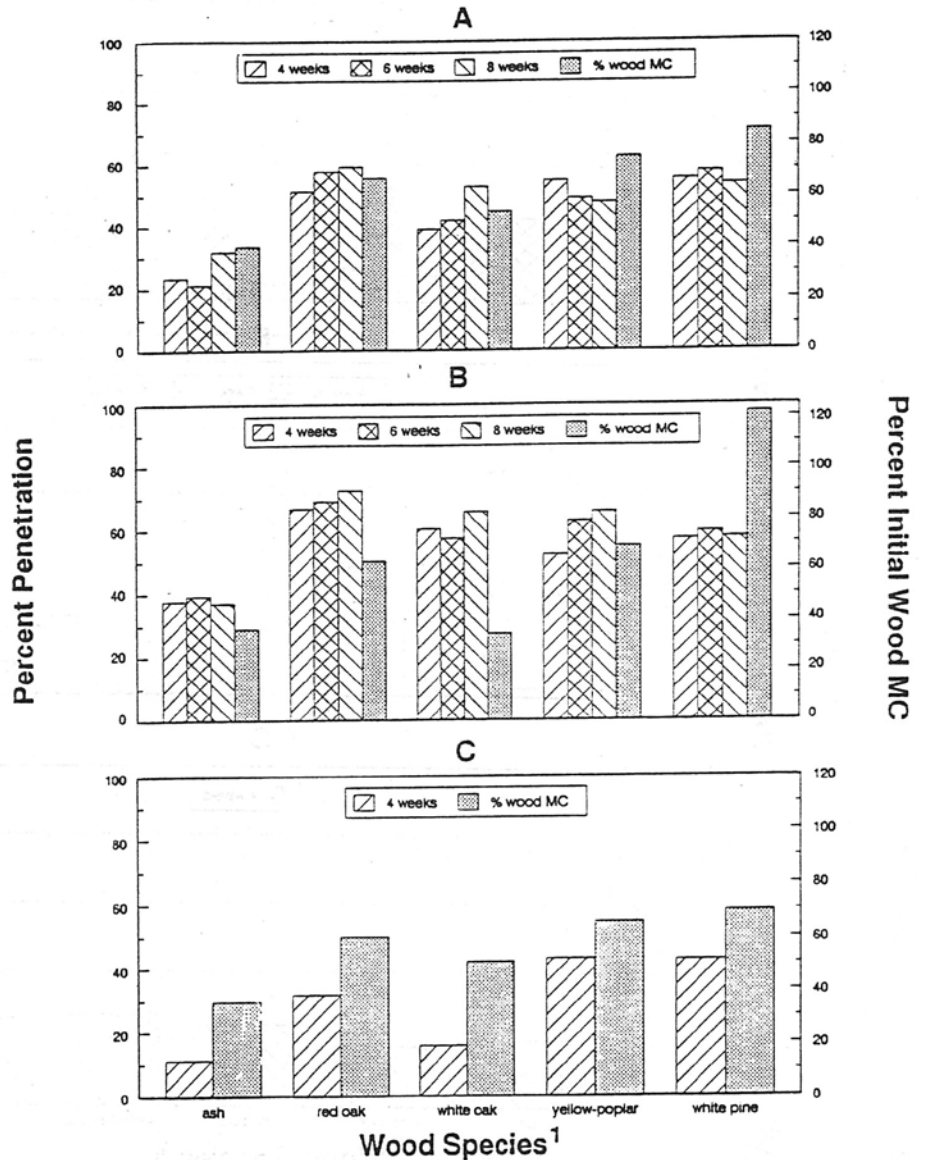

<sup>1</sup> After each species the dimensions listed represent those boards treated and indicate a different sawmill:

A. ash-8/4, 8/4, 5/4, 4/4; r.oak-8/4, 8/4, 8/4, 5/4, 4/4; w. oak-8/4, 4/4; y.poplar-8/4, 8/4, 5/4; w. pine-8/4

B. ash-8/4, 8/4, 8/4, 5/4, 4/4; r.oak-8/4, 8/4, 6/4, 5/4, 5/4, 4/4; w. oak-8/4, 4/4; y.poplar-8/4, 8/4, 5/4; w. pine-8/4

C. ash-8/4, 8/4; r.oak-8/4, 8/4, 5/4, 5/4; w. oak-4/4; y.poplar-8/4, 8/4, 8/4, 5/4; w. pine-8/4

Figure 4. — Combined mean percentages of boron penetration into board cross sections at 4, 6, and 8 weeks after dip-diffusion treatment with Tim-Bor during February (A), June (B), and October (C). Penetration based on color tests of board cross sections with a boron indicator. Boards were sampled from a varied number of sawmills and board thicknesses. Means represent for each month/species six board samples times the number of board dimensions listed in the footnote. Mean percent wood MC before treatment is also given.

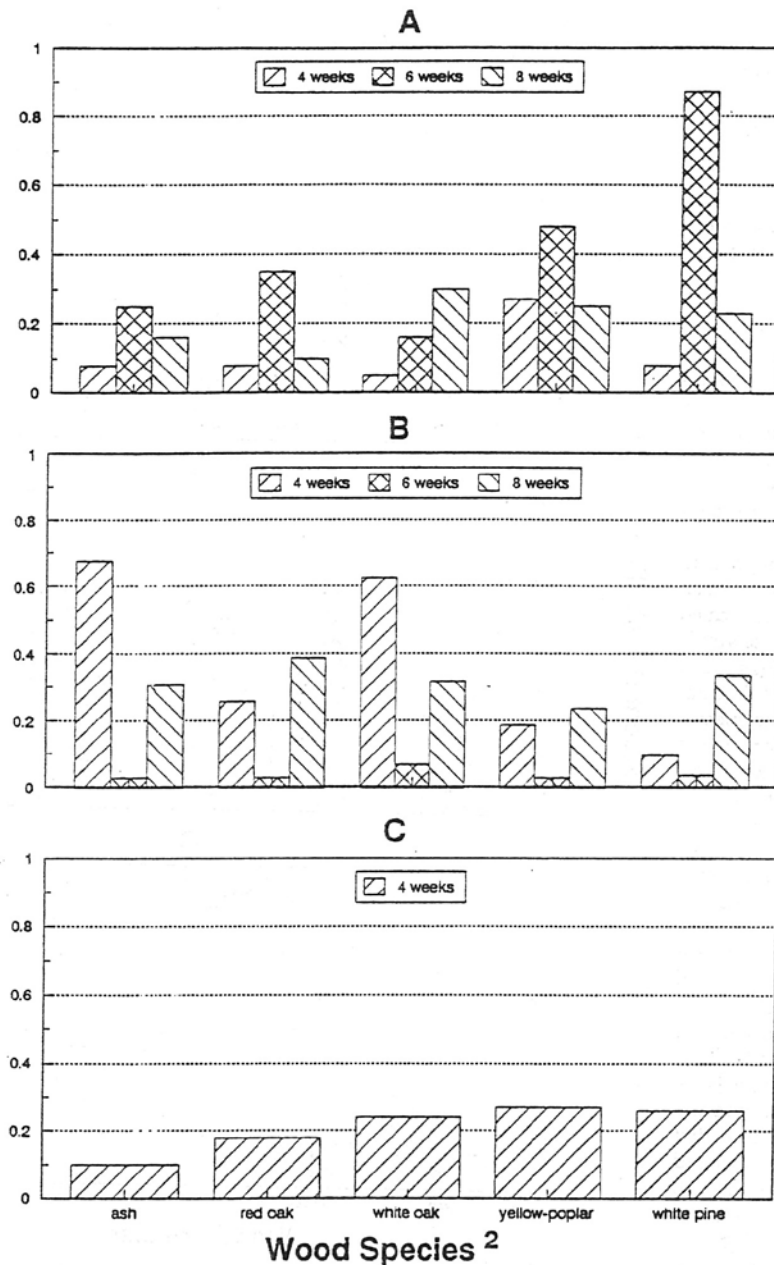

<sup>1</sup> analyzed at middepth in boards  
<sup>2</sup> After each species the dimensions listed represent those boards treated and indicate a different sawmill:  
 A. ash-8/4, 8/4, 5/4, 4/4; r.oak-8/4, 8/4, 8/4, 5/4, 4/4; w. oak-8/4, 4/4; y.poplar-8/4, 8/4, 5/4; w. pine-8/4  
 B. ash-8/4, 8/4, 8/4, 5/4, 4/4; r.oak-8/4, 8/4, 6/4, 5/4, 5/4, 4/4; w. oak-8/4, 4/4; y.poplar-8/4, 8/4, 5/4; w. pine-8/4  
 C. ash-8/4, 8/4; r.oak-8/4, 8/4, 5/4, 5/4; w. oak-4/4; y.poplar-8/4, 8/4, 8/4, 5/4; w. pine-8/4

Figure 5. — Combined mean percentages of BAE contents at middepth of boards at 4, 6, and 8 weeks after dip-diffusion treatment with Am-Bor-S during February (A), June (B), and October (C). Boards were sampled from a varied number of sawmills and board thicknesses. Means represent for each month/species three board samples times the number of board dimensions listed in the footnote.

no sawmill cut the lumber more than 3 days before it was treated. Only the MCs in yellow poplar, white pine, and occasionally oak lumber were exceptions to this trend. The MC of ash and white oak lumber often were below 40 percent, too low for good borate diffusion.

**Borate contents**

The mean BAE contents at board center across all mills where each species was treated with Am-Bor-S are given in Figure 5. Similar to the mean BAE contents following treatment with Tim-Bor are given in Figure 6. When one examines these data, a disturbing fact is the lack of consistent trends in the February and June data. The BAE content should increase with diffusion time, but this happened only for Am-Bor-S-treated white oak in February, Tim-Bor-treated ash in February, and white oak in June.

Another disturbing fact is the great difference in 6-week BAEs of both borates for a species when data for February and June are compared. The conclusion is that the 6-week BAE's in June are too low. All of the ICP analyses for the hundreds of samples in this study were done by contract. During this time, there was considerable turnover in contractor personnel and, no doubt, in sample-processing procedures. Assuming that the remaining analytical results are correct, then the 0.2 percent BAE level in board centers at both 4- and 8-week sampling periods was attained only in yellow-poplar in February (Figs. 5 and 6). In June, Am-Bor-S-treated lumber seemed to have the highest BAE levels (Figs. 5 and 6).

For lumber treated in October and covered for diffusion, 0.2 percent BAE in board centers was attained in Am-Bor-S-treated white oak, yellow-poplar, and white pine (Fig. 5) and Tim-Bor-treated yellow-poplar and white pine (Fig. 6). The 2.0 percent BAE level in red oak was nearly reached. This is a most promising result because red oak was treated at all six mills and contained unknown proportions of heartwood and sapwood, as did wood of all other species.

**Estimating solution consumption**

Because lumber dimensions were not uniform at all mills, the estimates of borate and solution consumption are intended only as a rough guide for solution use (Table 5). The estimates for mill numbers 2 and 5 should be

TABLE 4. — Mean (±S.D.) solution concentration by borate and month of treatment.\*

Borate	Mean (±S.D.) percent BAE		
	February	June	October
Am-Bor-S	30.7(±2.1)	31.5(±1.3)	35.1(±0.8)
Tim-Bor	31.8(±2.1)	30.7(±1.9)	35.3(±1.5)

\* For each borate and month, the means represent results of inductively coupled plasma-ion spectrograph analyses for boron content in solution samples taken before and after treatment at each of six mills, N = 12.

reasonably accurate because all treated boards were the dimensions used to estimate volumes. These estimates show that treatment of a packet of 4/4 or 5/4 (25 or 32 mm) lumber consumes more solution because it contains more wood surface area to absorb solution than does the same size packet of 8/4 (50 mm) lumber. For example, solution consumption at mills 4 and 6 when treating only 4/4 or 5/4 (25 or 32 mm) lumber averaged 21 to 28 gallons per 1,000 BF (33 to 44 liters/m<sup>3</sup>) for Am-Bor-S and 14 to 23 gallons (22 to 36 liters/m<sup>3</sup>) for Tim-Bor (Table 5). Consumption at the remaining mills for treatment of mostly 8/4 lumber ranged from 10 to 15 gallons per 1,000 BF (16 to 24 liters/m<sup>3</sup>).

### Conclusions

Based on the extensive, successful use of diffusion treatments for protection of hardwoods in Asian and South Pacific tropical regions, it would seem that this same technology should be appropriate for protection of Latin American tropical hardwoods. However, limited testing has been done to show that this premise is indeed true.

Despite problems with the experimental design and the BAE analyses, the results with mill-run lumber suggest that diffusion treatments are commercially feasible if domestic hardwood producers restrict drying for an as yet undefined period after treatment. Use of diffusion treatments with domestic hardwood lumber would be aided by development of suitable treatment processes for high-volume operations and by effective, environmentally acceptable additives that would prevent those fungi which cause discoloring.

### Literature cited

1. Amburgey, T.L. 1990. The need for co-biocides when treating wood with borates. First Inter. Conf. on Wood Protection with Diffusible Preservatives. Forest Products Res. Soc., Madison, Wis.
2. Anonymous. 1982. Eating away at your profits — the lyctid (powderpost) beetle. *Decor.* 102(10): 246-254.
3. Barnes, H.M. and L.H. Williams. 1988. Integrated protection against lyctid beetle infestations. V. Selecting efficient schedules for pressure treatment of tropical hardwood lumber with polyborates. *Forest Prod. J.* 38(9):13-19.
4. \_\_\_\_\_. 1988. Integrated protection against lyctid beetle infestations. VI. Thermal treatment of tropical hardwood lumber with polyborates. *Forest Prod. J.* 38(9):20-21.
5. Becker, G. 1976. Treatment of wood by diffusion of salts. *J. Inst. Wood Sci.* 7(4):30-36.
6. Borax Holdings Ltd. 1984. Tim-Bor® Preservative Plant Operators' Manual of Recommended Practice. Borax House, Carlisle Place, London, England.
7. Brooks, F.W. 1978. Wood preservation techniques for a better utilization of wood in developing rural areas. FID-II/22-7. In: Proc. from the World Forestry Congress. Jakarta, Indonesia.
8. Bunn, R. 1974. Boron compounds in timber preservation: an annotated bibliography. Tech. Pap. No. 60. Forest Res. Inst., New Zealand Forest

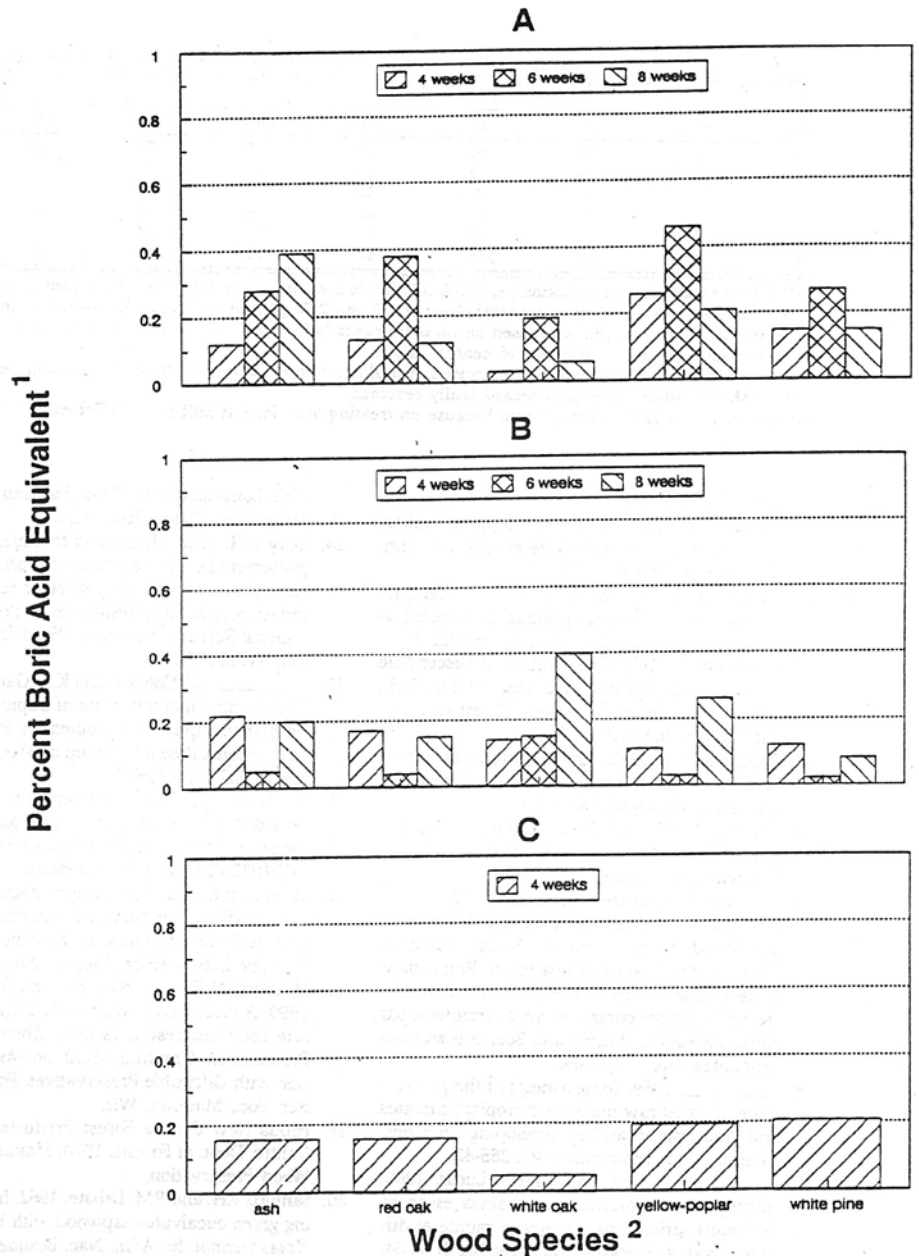

- 1 analyzed at middepth in boards
- 2 After each species the dimensions listed represent those boards treated and indicate a different sawmill:  
 A. ash-8/4, 8/4, 5/4, 4/4; r.oak-8/4, 8/4, 8/4, 5/4, 4/4; w. oak-8/4, 4/4; y.poplar-8/4, 8/4, 5/4; w. pine-8/4  
 B. ash-8/4, 8/4, 8/4, 5/4, 4/4; r.oak-8/4, 8/4, 6/4, 5/4, 5/4, 4/4; w. oak-8/4, 4/4; y.poplar-8/4, 8/4, 5/4; w. pine-8/4  
 C. ash-8/4, 8/4; r.oak-8/4, 8/4, 5/4, 5/4; w. oak-4/4; y.poplar-8/4, 8/4, 8/4, 5/4; w. pine-8/4

Figure 6. — Combined mean percentages of BAE contents at middepth of boards at 4, 6, and 8 weeks after dip-diffusion treatment with Tim-Bor during February (A), June (B), and October (C). Boards were sampled from a varied number of sawmills and board thicknesses. Means represent for each month/species three board samples times the number of board dimensions listed in the footnote.

TABLE 5. — Mean estimated consumption of borate and solution per mill for three treatments.<sup>a</sup>

Mill no.	Am-Bor-S				Tim-Bor			
	(gal.)	(L)	(lb.)	(kg)	(gal.)	(L)	(lb.)	(kg)
1	14	53	63	29	15	58	33	15
2	13	49	38	17	10	38	22	10
3	11	42	48	22	12	45	28	13
4 <sup>b</sup>	21	79	96	43	14	53	44	20
5 <sup>c</sup>	10	38	46	21	13	49	29	13
6	28	10 <sup>b</sup>	125	57	23	87	52	24

<sup>a</sup> All data are based on consumption per 1,000 BF (divide liters by 2.4 m<sup>3</sup> for liters/m<sup>3</sup>); pounds of consumption were calculated using solution concentrations of 4.5 and 2.25 pounds per gallon for Am-Bor-S and Tim-Bor, respectively. Consumption was based on measurements before and after treatment of solution depth when 1 inch equals 22 gallons, rounded to nearest gallon.

<sup>b</sup> Means do not include February data because at mill no. 4 snow and ice melting from lumber being treated replenished solution levels and caused faulty readings.

<sup>c</sup> Means do not include February data because no treating was done at mill no. 5 in February.

- Serv. Rotorua, N.Z.
9. Chandra, A. and S.C. Pant. 1981. Building timbers — treatment by nonpressure methods. *J. Tim. Dev. Assoc. (India)*. 27:23-29.
  10. Cockcroft, R. and J.F. Levy. 1973. Bibliography on the use of boron compounds in the preservation of wood. *J. Inst. Wood Sci.* 6(3):28-37.
  11. Coudreau, J. 1958. Preservation of susceptible tropical timbers against attack by lyctidae. *Tech. Note No. 2. Centre Technique Forestier Tropical. Nogent-Sur-Marne, France.*
  12. Espinoza, F.G. 1962. Impregnacion por immersion en pentaborato de sodio en tres maderas de Chile. *Maderero*. No. 3:13-15.
  13. Findlay, W.P.K. 1985. Preservation of Timber in the Tropics. *Martinus Nijhoff/Dr. W. Junk. Whitchurch, England.*
  14. Food and Agriculture Organization. 1986. Wood preservation manual. *Forestry Paper 76. Mechanical Wood Products Branch, Forest Industries Division, FAO Forestry Department, Rome, Italy.*
  15. Fougereuse, M. 1967. Preservation des menuiseries interieure contre les lyctus, traitement par trempage rapide et diffusion. *Bois et Forets des Tropiques*. No. 112:57-69.
  16. \_\_\_\_\_ 1969. Some aspects of the preservation of wood raw material in tropical climates and their importance for developing countries. *Material und Organismen* 4(3):255-82.
  17. \_\_\_\_\_, P. Lanthony, and S. Lucas. 1962. Impregnation profonde de certaines essences de l'ouest africain par trempage rapide et diffusion. *Bois et Forets des Tropiques*. No. 84:45-64.
  18. Francis, C.R. 1986. Timber preservation standards. UNIDO-ID/WG.447/14. *In: Proc. of the Expert Group Meeting on Timber Construction. United Nations Industrial Development Organization, Vienna, Austria.*
  19. Gonet, P. 1965. Impregnation of wood by short-term dipping. *Inf. Tech. Inst. For., Santiago*. 21:109-113.
  20. Hong, L.T., M.K. Tam, K. Daljeet-Singh, and S. Salamah. 1987. Protection and preservation options for rubberwood sawn timber and finished products. *In: Proc. of the 2nd Rubberwood Seminar. Kuala Lumpur. Kepong, Malaysia.* 49-61.
  21. \_\_\_\_\_ and C.C.K. Liew. 1989. Protection of rubberwood timber. I. Impregnation with boron preservatives. IRG/WP/3551:11. *In: International Research Group on Wood Preservation.*
  22. Jayanetti, D.L. 1978. A guide to boron diffusion treatment. FID-II/22-1:14. *In: Proc. of the Eighth World Forestry Congress. Jakarta, Indonesia.*
  23. LaFage, J.P. and L.H. Williams. 1979. Lyctid beetles. Recognition, prevention, control. *LSU Circ.* 106. Louisiana Agri. Expt. Sta. and Louisiana State Univ., Baton Rouge, La.
  24. Levy, C.R. 1982. Methods of treatment of wood preservatives. The selection of appropriate preservation process with particular reference to mixed tropical forest resources. *In: Proc. of International Research Group on Wood Preservation. IRG/WP/3177:10.*
  25. \_\_\_\_\_, S.J. Colwell, and K.A. Garbutt. 1972. The dip diffusion treatment of tropical building timbers in Papua New Guinea. *In: Proc. of the International Research Group on Wood Preservation. IRG/WP/310:67.*
  26. McQuire, A.J. 1978. Forestry for industrial development—wood preservation for the rural sector. *In: Proc. Eighth World Forestry Congress. FID-II/22-12:8. Jakarta, Indonesia.*
  27. Melo, R. and J. Paz. 1966. Impregnacion de madera con solucion de borax acido borico aplicando el metodo de immersion momentanea. *Boletin. Inst. For. Latino Amer., Merida*. No. 20-21:32-8.
  28. Mitchoff, M.E., L.H. Williams, and R.L. Nance. 1990. A video image system for converting borate color test results to data. *Abstract Poster Presentation. First Inter. Conf. on Wood Protection with Diffusible Preservatives. Forest Prod. Res. Soc., Madison, Wis.*
  29. Papua New Guinea Forest Products Research Centre, Dept. of Forests. 1974. *Manual of Rural Wood Preservation.*
  30. Santoro, F.H. and P.M. Labate. 1962. Impregnating green eucalyptus sapwood with boric acid. *Notas technol. for Adm. Nac. Bosques, Buenos Aires*. 17:5 pp.
  31. Sonti, V.R. and B. Chatterjee. 1983. Study on the treatment of construction timbers by diffusion methods. IRG/WP/3252:3. *International Research Group on Wood Preservation.*
  32. Supriana, N. and T.K. Waluyo. 1987. The treatability of five Indonesian wood species with BFCA preservative. IRG/WP/3428:11. *International Research Group on Wood Preservation.*
  33. Tamblin, N., S.J. Colwell, and G.N. Vickers. 1968. Preservative treatment of tropical building timbers by a dip-diffusion process. *Proc. British Commonwealth Forestry Conf. Reprinted CSIRO Australia, Div. of Forest Prod. Reprint 725.*
  34. Williams, L.H. and J.P. LaFage. 1979. Tracking the lyctid beetle. *Southern Lumberman*. 239(2968):112.
  35. \_\_\_\_\_ 1985. Integrated protection against lyctid beetle infestations. I. the basis for developing beetle preventive measures for use by hardwood industries. *USDA Forest Serv., Southern Forest Expt. Sta., New Orleans, La.*
  36. \_\_\_\_\_ 1987. Wood-inhabiting insects and their control: producer and user viewpoints. *In: Wood Protection Techniques and the Use of Treated Wood in Construction, Proc. 47258. Forest Prod. Res. Soc., Madison, Wis.*
  37. \_\_\_\_\_ and J.K. Mauldin. 1985. Integrated protection against lyctid beetle infestations Part II. Laboratory dip-diffusion treatment of unseasoned banak (*Virola* spp.) lumber with boron compounds. *Res. Note SO-313. USDA Forest Serv., Southern Forest Expt. Sta., New Orleans, La.*
  38. \_\_\_\_\_, T.L. Amburgey, and R. Yates. 1985. Forest Service mobile equipment tests borate dip-diffusion treatment of wood. *News Release. USDA Forest Serv., Southern Forest Expt. Sta. New Orleans, La.*
  39. \_\_\_\_\_ and \_\_\_\_\_ 1987. Integrated protection against lyctid beetle infestations. IV. Resistance of boron-treated wood (*Virola* spp.) to insect and fungal attack. *Forest Prod. J.* 37(2): 10-17.

**APPENDIX 4**  
**COST ESTIMATE**

RESTORATION OF AYUGUTHI SATTAL, MANGAL BAZAR.

S.NO.	DESCRIPTION OF WORKS	NO.	L.	B.	H.	QT.	TOTAL QT.	UNIT	RATE	AMOUNT Rs.	REMARKS
1.	Dismantling roof, walls, windows (numbering parts of windows for refixing) and usable materials storing.	---	---	---	---	---	L/S	---	---	35,000.00	
2.	Site clearance.	---	---	---	---	---	L/S	---	---	20,000.00	
3.	Double layer scaffolding.	1	103'0"	---	19'0"	---	1,957.00	Sq.ft.	25.00	48,925.00	
4.	Damp proof course (Wall area)	1 1	33'6" 56'6"	2'0" 1'6"	---	67.00 84.75	151.75	Sq.ft.	225.00	34,143.75	
5.	Brick soling.	1	30'6"	8'0"	---	---	244.00	Sq.ft.	10.00	2,440.00	
6.	Plasfal's DPC (Floor area)	1	30'6"	8'0"	---	---	244.00	Sq.ft.	40.00	9,760.00	
7.	6"x6" Floor tile in on sand and mud.	1	30'6"	8'6"	---	---	259.25	Sq.ft.	57.00	14,777.25	
8.	Repair of main entrance door.	1	---	---	---	---	1	Nos.	L/S	4,000.00	
9.	New carving of small window on south elevation, east corner.	1	---	---	---	---	1	Nos.	5,000.00	5,000.00	
10.	New carving of main front pillars with brackets.	4	---	---	---	---	4	Nos.	18,000.00	72,000.00	
										<b>246,046.00</b>	



S.NO	DESCRIPTION OF WORKS	NO.	L.	B.	H.	QT.	TOTAL QT.	UNIT	RATE	AMOUNT Rs.	REMARKS
11.	Plain timber work. a) Beam above pillar. b) Inside pillars. c) Lintel for window. d) Lintel for door. e) Lower wall plates. -f) Joist @ 1'c/c g) Window sill (middle). h) Window lintel (middle). i) Side window sill. j) Side window lintel. k) Door lintel. l) Inside pillar in big window. m) Wall plates below upper level joists. n) Joist @ 1'c/c o) Wall plates below rafter. p) Rafters (front). q) Rafters (back). r) Ridge beam. s) Pillar for ridge beam. t) Base for pillar ( <i>lakasi</i> ). u) Purlin ( <i>chalu</i> ). v) Eaves beam.	2 4 3 3 2 2 30 2 3 2x2 2x3 3 4 2 2 30 2x2 2x2 34 34 1 4 1 2 36	17'0" 0'8" 3'6" 3'6" 34'0" 8'6" 11'6" 12'0" 12'0" 4'0" 4'6" 4'6" 0'6" 34'0" 8'6" 11'6" 34'0" 12'0" 11'0" 9'0" 34'0" 0'5" 34'0" 34'0" 34'0" 5'0"	0'8" 0'8" 0'4" 0'4" 0'4" 0'4" 0'3" 0'4" 0'3" 0'4" 0'3" 0'4" 0'6" 0'4" 0'4" 0'4" 0'4" 0'4" 0'3" 0'5" 0'5" 0'5" 0'4" 0'4" 0'3" 0'3"	15.081 12.420 0.875 0.875 5.667 1.417 28.75 2.00 3.00 1.333 2.250 1.125 5.00 5.667 1.417 38.75 11.333 4.00 31.167 25.50 5.884 3.807 4.709 5.667 15.00				246,046.00		
12.	Eaves board	2	34'0"	-----	0'6"	-----	34.00	Sq.ft.	200.00	6,800.00	
							232.694	Cu.ft.	1650.00	383,945.10	
											<b>636,791.10</b>

S.NO	DESCRIPTION OF WORKS	NO.	L.	B.	H.	QT.	TOTAL QT.	UNIT	RATE	AMOUNT Rs.	REMARKS
										<b>636,791.10</b>	
13.	Repair of <i>sanjhya</i> .	1	-----	-----	-----	-----	1	Nos.	L/S	25,000.00	
14.	Repair of planking windows and installation.	2	-----	-----	-----	-----	2	Nos.	5,000.00	10,000.00	
15.	Staircase	2	-----	-----	-----	-----	2	Nos.	12,000.00	24,000.00	
16.	Repair of struts, cleaning, + fixing.	7	-----	-----	-----	-----	7	Nos.	1,000.00	7,000.00	
17.	Brick work ( <i>daci-apa</i> ) on main facade.	1	33'6"	-----	16'0"	536.00					
	Sq. ft. deduct - Door	1	3'0"	-----	4'9"	-14.25					
	Small window	1	2'0"	-----	2'0"	- 4.00					
	Dalan	1	15'0"	-----	6'6"	-97.50					
	Big window	1	10'0"	-----	6'0"	-60.00					
	Side window	2	3'0"	-----	3'9"	-22.50					
18.	Cornice above dalan	1	33'6'	-----	-----	-----	337.75	Sq.ft.	250.00	84,437.50	
20.	Fix niches on wall with existing sculpture	-----	-----	-----	-----	-----	33'6"	R.ft.	300.00	10,050.00	
									L/S	5,000.00	
										<b>802,278.60</b>	

S.NO	DESCRIPTION OF WORKS	NO.	L.	B.	H.	QT.	TOTAL QT.	UNIT	RATE	AMOUNT Rs.	REMARKS
21.	Ma-apa brick wall in mud. a) Back wall b) Side walls c) Front (without <i>daci-apa</i> wall) deduct: - Door Small window Dalan Big window Side window	1 2 1 1 1 1 1 1 2	33'6" 8'0" 33'6" 3'0" 2'0" 15'0" 10'0" 3'0"	2'0" 1'9" 1'5" 1'5" 1'5" 1'5" 1'5" 1'5"	16'0" 19'0" 16'0" 4'9" 2'0" 6'6" 6'0" 3'9"	1,072.00 532.00 758.976 -20.178 -5.664 -138.06 -84.96 -31.86	2082.254	Cu.ft.	85.00	176,991.59	
22.	3 layers of planking a) On first floor and top floor	2	30'6"	8'0"		488.00	488.00	Sq.ft.	540	263,520.00	
23.	Above eaves beam 1 layer	1	33'6"	3'6"		117.25	177.25	Sq.ft.	180	31,905.00	
										<b>1,274,695.20</b>	

S.NO	DESCRIPTION OF WORKS	NO.	L.	B.	H.	QT.	TOTAL QT.	UNIT	RATE	AMOUNT Rs.	REMARKS
										<b>1,274,695.20</b>	
24.	2 layer's of plastic above planking of 1st fl. & top fl.	2	30'6"	8'0"	-----	-----	488.00	Sq.ft.	25.00	12,200.00	
25.	Mud flooring	2	30'6"	8'0"	-----	-----	488.00	Sq.ft.	50.00	24,400.00	
26.	Lath on rafters	1	33'6"	20'0"	-----	-----	670.00	Sq.ft.	140	93,800.00	
27.	2 layers of plasfal on roof lath as moisture protector	1	33'6"	20'0"	-----	-----	670.00	Sq.ft.	80.00	53,600.00	
28.	Jhingati on mud bed	1	33'6"	20'0"	-----	-----	670.00	Sq.ft.	50.00	33,500.00	
29.	Karmex + Alchohol for mud treatment.	-----	-----	-----	-----	-----	7	Kg.	1,500.00	10,500.00	
30.	Ridge tile.	1	73'6"	-----	-----	-----	73'6"	R.ft.	95.00	6,982.50	
31.	Dormer: (materials and labour )	1	-----	-----	-----	-----	1	Nos.	L/S	15,000.00	
32.	Glazed shutters for window. a) Big window. b) Side windows.	1 2	10'0" 3'0"	----- -----	6'0" 3'9"	60.00 22.50	82.50	Sq.ft.	250.00	20,625.00	
33.	Peti stone (plinth).	1	52'0"	-----	-----	-----	52.00	R.ft.	300.00	20,800.00	
34.	Peti repair (plinth).	1	-----	-----	-----	-----	1	-----	L/S	10,000.00	
35.	Site clearance	1	-----	-----	-----	-----	1	-----	L/S	15,000.00	
	<b>Total Rs.</b>									<b>1,591,102.70</b>	

S.NO	DESCRIPTION OF WORKS	NO.	L.	B.	H.	QT.	TOTAL QT.	UNIT	RATE	AMOUNT Rs.	REMARKS
	<b>Total Rs.</b>									<b>1,591,102.70</b>	
	+10% Inflation									159,110.27	
	+ 25% Contingency									397,775.68	
	<b>Grand Total in Rs.</b>									<b>2,147,988.65</b>	
	<b>Amount in Dollar @ of Rs. 55.25 per Dollar in March '96</b>									<b>\$ 38,877.62</b>	



© 2013 THE KATHMANDU VALLEY PRESERVATION TRUST

KVPT – UNITED STATES

36 West 25th Street - 17th Floor  
New York, New York 10010, USA

TEL: +1 212 727 0074

EMAIL: [susannah@kvptnepal.org](mailto:susannah@kvptnepal.org)

KVPT-NEPAL

P.O.Box 13349  
Kathmandu, Nepal

TEL: +977 1 55 46 055

EMAIL: [info@kvptnepal.org](mailto:info@kvptnepal.org)

[kvptnepal.org](http://kvptnepal.org)